

Smart choice for power

xantrex

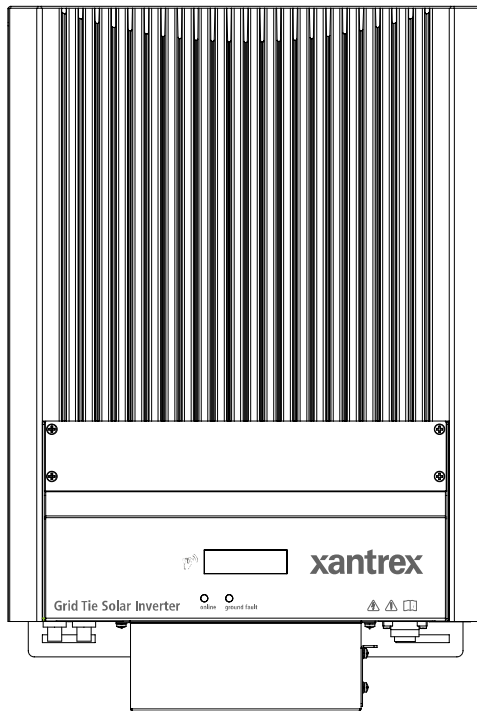

GT2.8-AU-QC-230
GT5.0-AU-QC-230

Owner's Manual

Xantrex Grid Tie Solar Inverter

www.xantrex.com

Xantrex Grid Tie Solar Inverter

Owner's Manual

About Xantrex

Xantrex Technology Inc. (www.xantrex.com), a subsidiary of Schneider Electric, is a world leader in the development, manufacturing and marketing of advanced power electronic products and systems for the renewable and mobile power markets. The company's products convert and control raw electrical power from any central, distributed, renewable, or backup power source into high-quality power required by electronic equipment and the electricity grid. Xantrex is headquartered in Vancouver, Canada, with facilities in the United States, Germany, Spain, and a joint venture in China.

Trademarks

Xantrex and XPower are trademarks of Schneider Electric Services International sprl, registered in the U.S. and other countries.

Other trademarks, registered trademarks, and product names are the property of their respective owners and are used herein for identification purposes only.

Notice of Copyright

Copyright © April 2009 Xantrex Technology Inc. No part of this document may be reproduced in any form or disclosed to third parties without the express written consent of:

Xantrex Technology Inc.
161-G South Vasco Road
Livermore, California
USA 94551

Xantrex Technology Inc. reserves the right to revise this document and to periodically make changes to the content hereof without obligation or organization of such revisions or changes unless required to do so by prior arrangement.

Exclusion for Documentation

Unless specifically agreed to in writing, Xantrex Technology Inc. ("Xantrex")

(A) MAKES NO WARRANTY AS TO THE ACCURACY, SUFFICIENCY OR SUITABILITY OF ANY TECHNICAL OR OTHER INFORMATION PROVIDED IN ITS MANUALS OR OTHER DOCUMENTATION.

(B) ASSUMES NO RESPONSIBILITY OR LIABILITY FOR LOSSES, DAMAGES, COSTS OR EXPENSES, WHETHER SPECIAL, DIRECT, INDIRECT, CONSEQUENTIAL OR INCIDENTAL, WHICH MIGHT ARISE OUT OF THE USE OF SUCH INFORMATION. THE USE OF ANY SUCH INFORMATION WILL BE ENTIRELY AT THE USER'S RISK; AND

(C) REMINDS YOU THAT IF THIS MANUAL IS IN ANY LANGUAGE OTHER THAN ENGLISH, ALTHOUGH STEPS HAVE BEEN TAKEN TO MAINTAIN THE ACCURACY OF THE TRANSLATION, THE ACCURACY CANNOT BE GUARANTEED. APPROVED XANTREX CONTENT IS CONTAINED WITH THE ENGLISH LANGUAGE VERSION WHICH IS POSTED AT WWW.XANTREX.COM.

Date and Revision

April 2009 Revision A

Document Part Number

975-0466-01-01

Product Part Numbers

864-1030 (GT2.8-AU-QC-230) and 864-1039 (GT5.0-AU-QC-230)

Contact Information

Telephone: 1 408 987 6030

Fax: 1 604 422 2756

Email: customerservice@xantrex.com

Web: www.xantrex.com

About This Manual

The purpose of this Owner's Manual is to provide explanations and procedures for installing, operating, maintaining, and troubleshooting the Xantrex Grid Tie Solar Inverter™.

Scope

The manual provides safety guidelines, detailed planning and setup information. It provides procedures for installing the inverter and information about operating and troubleshooting the unit. It does not provide details about particular brands of photovoltaic (PV) panels. You need to consult individual PV manufacturers for this information.

Audience

Chapter 1 and Chapter 5 are intended for anyone who needs to operate the Xantrex Grid Tie Solar Inverter. Operators must be familiar with all the safety regulations pertaining to operating high-voltage equipment as dictated by local code. Operators must also have a complete understanding of this equipment's features and functions. Do not use this product unless it has been installed by a qualified installer in accordance with the instructions in Chapter 2, "Installation".

Chapter 2, Chapter 3, Chapter 4, and Chapter 6 are intended for qualified installers who need to install the Xantrex Grid Tie Solar Inverter. Qualified installers have the training and experience in solar power systems to safely and correctly follow these instructions and the applicable electrical and building codes, in order to design and install a system that is safe and will operate correctly. Qualified installers have an awareness of the hazards involved in performing electrical installation work and how to reduce those hazards. Only qualified personnel should perform the installation, commissioning and maintenance of the GT Inverter.

Organization

This manual is organized into 6 chapters and an appendix.

Chapter 1, "Introduction", contains information about the features and functions of the Xantrex Grid Tie Solar Inverter.

Chapter 2, "Installation", provides information about planning for and installing the GT Inverter. It contains information to help you plan wire routes, ensure your PV array provides necessary power, and find a suitable location for installation.

Chapter 3, “Wiring the Inverter”, provides procedures for making DC and AC wiring connections for single and multiple inverter installations. This chapter also includes information about communications wiring and using GT-View monitoring software.

Chapter 4, “Starting the Inverter”, contains information on starting up the Xantrex Grid Tie Solar Inverter and performing a functional test.

Chapter 5, “Monitoring the Inverter”, contains information for understanding the LCD screens and the LED indicators.

Chapter 6, “Maintenance and Troubleshooting”, contains information about how to provide general maintenance for the Xantrex Grid Tie Solar Inverter. It also provides information about troubleshooting the unit.

Appendix A, “Specifications”, contains information about the electrical and environmental specifications of the Xantrex Grid Tie Solar Inverter.

Conventions Used

The following conventions are used in this guide.



WARNING

Warnings identify conditions that could result in personal injury or loss of life.



CAUTION

Cautions identify conditions or practices that could result in damage to the unit or other equipment.







Important: These notes describe things that are important for you to know, but not as serious as a caution or warning.

Abbreviations Used

GT	Grid Tie
I _{SC}	Short Circuit Current
LCD	Liquid Crystal Display
LED	Light Emitting Diode
MPPT	Maximum Power Point Tracking
P _{MAX}	Maximum Output Power
P _{NOM}	Nominal Output Power

PC	Personal Computer
PV	Photovoltaic
STC	Standard Test Condition
Vac	Volts AC
Vdc	Volts DC
V _{MP}	Voltage at Maximum Power
V _{OC}	Open Circuit Voltage
U _{PV}	PV Array DC Voltage

Symbols Used

	Alternating Current (AC)
	Direct Current (DC)
	In this guide: Important information, warnings, or cautions. On the product: Important information, warnings or cautions with further explanation in the product guide.
	On the product: Warning, risk of electric shock.
	On the product: Warning, Hot surface—risk of burns.
 30 min.	FOR AUTHORIZED SERVICE PERSONNEL: Before opening cover, disconnect DC and AC power and wait 30 minutes to allow internal voltages to reach safe levels. NOTE: there are no user-serviceable parts inside.
	Refer to the operating instructions.

Related Information

You can find more information about Xantrex Technology Inc. as well as its products and services at www.xantrex.com

Important Safety Instructions



WARNING: Save these instructions

This manual contains important safety and operating instructions. Read and keep this Owner's Manual for future reference.



WARNING: Limitations on use

Do not use this GT Inverter in connection with life support systems, medical equipment, or where human life or medical property may be at stake.

1. Before installing and using the GT Inverter, read all instructions and cautionary markings on the inverter and in all appropriate sections of this guide.
2. To reduce shock, fire, and energy hazards the installation must be in accordance with all applicable local installation codes. It is the installer's responsibility to ensure adherence to applicable codes.
3. To reduce risk of fire hazard, do not cover or obstruct the heat sink.
4. Observe the clearance recommendations as described on page 2–12. Do not install the GT Inverter in a zero-clearance or non-ventilated compartment. Overheating may result.
5. Use only accessories recommended or sold by the manufacturer. Doing otherwise may result in a risk of fire, electric shock, or injury to persons.
6. To avoid a risk of fire and electric shock, make sure that all wiring is in good condition and that wire is not undersized. Do not operate the GT Inverter with damaged or substandard wiring.
7. Do not operate the GT Inverter if it has received a sharp blow, been dropped, or otherwise damaged in any way. If the GT Inverter is damaged, see the Warranty section.
8. Do not disassemble the GT Inverter. It contains no user-serviceable parts. See Warranty for instructions on obtaining service. Attempting to service the GT Inverter yourself may result in a risk of electrical shock or fire and will void your warranty.
9. To reduce the risk of electrical shock, disconnect both AC and DC power from the GT Inverter before attempting any maintenance or cleaning or working on any circuits connected to the inverter. Turning off controls will not reduce this risk. Internal capacitors remain charged for up to 30 minutes after disconnecting all sources of power.
10. The GT Inverter must be provided with an equipment-grounding conductor connected to the AC ground.

Regulatory Compliance

The GT Inverter is compliant with the standards described below.

- Safety: Regulatory Compliance Mark (RCM) based on compliance with AS/NZS 3100 *Approval and test specification – General requirements for electrical equipment*
- Electromagnetic Compatibility (EMC): RCM mark based on compliance with:
 - EN61000-6-1 *Generic standards – Immunity for residential, commercial, and light-industrial environments*
 - EN61000-6-3 *Generic standards – Emission standard for residential, commercial, and light-industrial environments*
 - EN61000-3-2 *Limits for harmonic current emissions*
 - EN61000-3-3 *Limitations of voltage changes, voltage fluctuations, and flicker*
- Interconnect: ResLab verified, compliant with the following:
 - AS 4777.2-2005 *Grid connection of energy systems via inverters – Inverter requirements*
 - AS 4777.3-2005 *Grid connection of energy systems via inverters – Grid protection requirements*

The GT Inverter is designed for utility interactive operation. It has complete on-board over-current, over-temperature and anti-islanding protection. It monitors voltage and frequency of the utility grid and automatically stops supplying power whenever conditions on the utility grid deviate from standard levels (see Specifications).

The GT Inverter is equipped with a high frequency transformer that assures galvanic isolation between the DC side and the utility power grid.

PV Ground Fault Detection

The GT Inverter is equipped with a ground fault detection circuit that measures the impedance to ground of the array, before connecting to the grid. If a high impedance is not detected, it signals a fault and refuses to connect. The GT Inverter will remain faulted until the ground fault is remedied and the inverter is manually reset. See Table 6-1, “Troubleshooting the GT Inverter” on page 6-4.

Contents

Important Safety Instructions	vii
Regulatory Compliance	viii
PV Ground Fault Detection	viii
1 Introduction	
About the Xantrex Grid Tie Solar Inverter	1-2
Standard Features	1-3
2 Installation	
Installation Options	2-2
Single Inverter Installation	2-2
Multiple Inverter Installations	2-2
Planning the Installation	2-2
Inverter Location	2-4
PV Array Requirements	2-5
Grounding Requirements	2-7
Routing the Wires	2-8
Preparing for the Installation	2-8
Wiring	2-8
AC Circuit Breaker Requirements	2-9
AC and DC Disconnects	2-9
Mounting the Inverter	2-9
Overview	2-9
Tools and Materials Needed	2-10
Dimensions	2-11
Installing the Mounting Bracket	2-12
Mounting the Inverter on the Bracket	2-16
3 Wiring the Inverter	
Connecting the DC Wiring	3-2
Equipment Needed	3-3
DC Fuses (GT5.0-AU Model Only for Three PV Strings)	3-3
Connecting the PV Array	3-4

Connecting Multiple Inverters	3-6
Connecting the AC Wiring-	3-7
Making AC Connections for the GT2.8-AU Model	3-7
Making AC Connections for GT5.0-AU Model	3-9
Communications Wiring for Multiple Inverters	3-10
Xanbus Network Technology	3-11
Guidelines for Routing the Network Cables	3-13
Connecting Network Cable between Inverters	3-14
Verifying the Xanbus Network	3-15
Communications Wiring for Monitoring a Single Inverter-	3-16
4 Starting the Inverter	
Commissioning Procedure	4-2
Disconnect Test	4-3
5 Monitoring the Inverter	
Monitoring the Front Panel Display	5-2
Front Panel Display Screens and What They Mean	5-3
Startup Mode	5-3
Normal Operation Mode	5-5
Offline Mode	5-7
Fault Mode	5-8
Special Screens	5-10
Custom Screens	5-10
Status Indicator Lights	5-11
6 Maintenance and Troubleshooting	
Factors Affecting GT Inverter Performance	6-2
PV Array Factors	6-2
Other Factors	6-3
Performing General Maintenance	6-3
Identifying Error/Fault Conditions and Solutions	6-3
A Specifications	
Electrical Specifications	A-2
Input	A-2
Output	A-2
Islanding Protection	A-3
Adjustable Disconnect Settings	A-3
Output Power Versus Ambient Temperature	A-4
Efficiency	A-5

Environmental Specifications	A-5
User Display	A-5
Display Accuracy	A-5
Mechanical Specifications	A-5
Warranty and Return Information	WA-1
Index	IX-1

Figures

Figure 1-1	Basic System Overview	1-2
Figure 1-2	Main Features of the GT Inverter (GT2.8-AU Model Shown)	1-4
Figure 2-1	Installation Options Overview	2-3
Figure 2-2	GT Inverter mounting orientation	2-5
Figure 2-3	Installation Overview	2-10
Figure 2-4	GT Inverter Dimensions (GT5.0-AU shown)	2-11
Figure 2-5	Mounting Bracket and GT Inverter	2-12
Figure 2-6	Examples of Mounting on a Pole or Rails	2-14
Figure 2-7	Installing the Mounting Bracket using Plywood Support	2-15
Figure 2-8	Proper Placement of the Inverter on the Mounting Bracket	2-16
Figure 3-1	PV Quick Connect Locations	3-2
Figure 3-2	GT5.0-AU DC Fuse Installation	3-4
Figure 3-3	DC Connections for a Two-String PV Array	3-5
Figure 3-4	Improper Multiple Inverter Connections	3-6
Figure 3-5	AC Connector (Female)	3-8
Figure 3-6	AC Connector Terminals	3-8
Figure 3-7	GT5.0-AU AC Wiring Compartment and Terminal Block	3-9
Figure 3-8	Network Layout (Communication Ports Cover Not Installed)	3-11
Figure 3-9	Network Terminator	3-12
Figure 3-10	Location of Xanbus RJ45 Ports	3-12
Figure 3-11	Network Cable	3-13
Figure 3-12	Replacing the Communication Ports Cover	3-15
Figure 5-1	Front Panel LCD Location	5-2
Figure 5-2	Location of Status Indicator Lights	5-11
Figure A-1	Output Power vs. Ambient Temperature (GT2.8-AU)	A-4
Figure A-2	Output Power vs. Ambient Temperature (GT5.0-AU)	A-4

Tables

Table 2-1	MPPT Operational Window (GT2.8-AU) -----	2-6
Table 2-2	MPPT Operational Window (GT5.0-AU) -----	2-6
Table 2-3	Inverter Clearance Requirements -----	2-12
Table 3-1	Recommended Fuses -----	3-3
Table 3-2	Total Xanbus Network Length -----	3-11
Table 3-3	Network Components and Part Numbers-----	3-13
Table 5-1	Startup Screens on GT5.0-AU Front Panel Display-----	5-3
Table 5-2	Normal Operation Default Screen -----	5-5
Table 5-3	Normal Operation Screens for All GT Inverters -----	5-6
Table 5-4	Additional Normal Operation Screens for Each GT Inverter in a Multiple Unit System -	5-7
Table 5-5	Offline Mode Default Display -----	5-7
Table 5-6	Offline Mode Screens for All GT Inverters -----	5-7
Table 5-7	Additional Offline Mode Screens for Each GT Inverter in a Multiple Unit System ----	5-8
Table 5-8	Fault Message Screens -----	5-8
Table 5-9	Additional Fault Mode Screens -----	5-9
Table 5-10	Special Message Screens -----	5-10
Table 5-11	Status Indicator LEDs -----	5-11
Table 6-1	Troubleshooting the GT Inverter -----	6-4

1

Introduction

Chapter 1, “Introduction”, contains information about the features and functions of the Xantrex Grid Tie Solar Inverter.

The topics in this chapter are organized as follows:

- “About the Xantrex Grid Tie Solar Inverter” on page 1–2
- “Standard Features” on page 1–3

About the Xantrex Grid Tie Solar Inverter

The Xantrex Grid Tie Solar Inverter (GT Inverter) is designed to convert solar electric (photovoltaic or PV) power into utility-grade electricity that can be used by the home or sold to the local power company.

Installing the GT Inverter consists of mounting it to the wall and connecting the DC input to a PV array and the AC output to the utility. See Figure 1-1 for a simple diagram of a typical installation.

In order to operate, the GT Inverter must have grid power available and connected. It will not provide backup power if the AC grid fails.

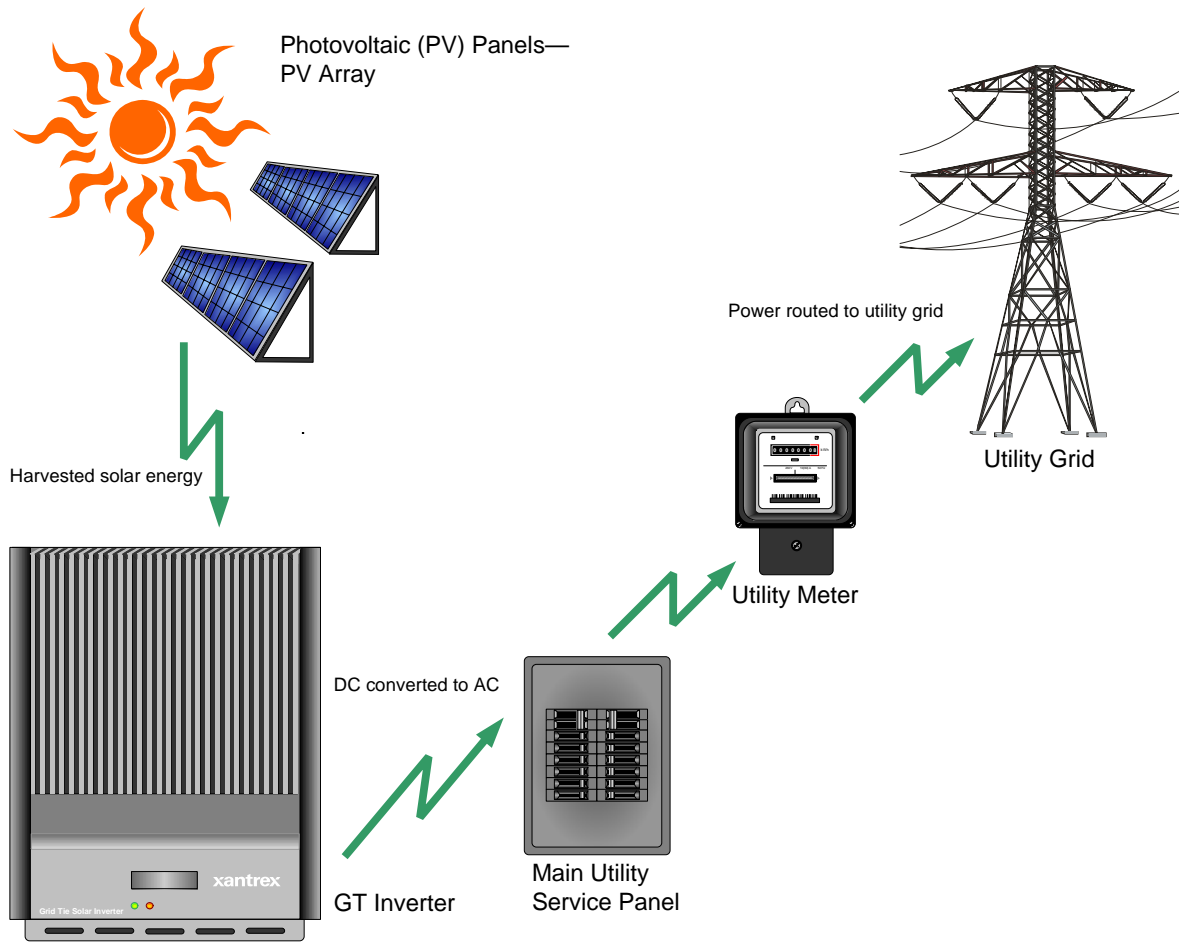

Figure 1-1 Basic System Overview

PV compatibility	The GT Inverter is designed to take advantage of solar modules configured as high voltage PV string arrays—single crystalline, poly crystalline, or thin film—with a 195 to 550 Vdc output voltage Maximum Power Point range (240 to 550 Vdc for the GT5.0-AU model).
Maximum Power Point Tracking (MPPT)	The GT Inverter uses Xantrex proprietary Maximum Power Point Tracking (MPPT) technology to harvest the maximum amount of energy from the solar array. MPPT learns your array’s specific characteristics, maximizing its output at all times.
High efficiency	The high-frequency, solid-state design of the GT Inverter is extremely efficient—up to 96%.
Expandable	Multiple GT Inverters may be networked together for increased net metering capacity or future system growth.
Communications protocol	The GT Inverter uses the Xanbus [®] communications protocol, enabling it to communicate with multiple units connected within the system. For more information, see “Xanbus Network Technology” on page 3–11.

Standard Features

The GT Inverter has the following standard features:

- Sealed inverter (IP54) with external heat sink to protect power electronic components
- Quick-connect connections for DC input (both models) and for AC output (GT2.8-AU model only)
- Liquid Crystal Display (LCD) to provide easy-to-read system status and daily cumulative energy production information
- Two LED indicator lights to provide status and ground fault indication.

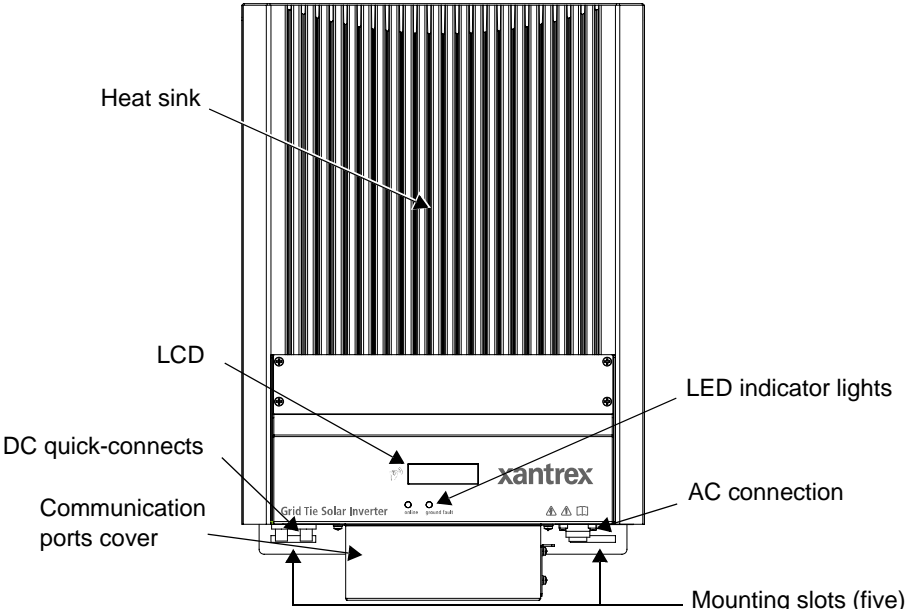

Figure 1-2 Main Features of the GT Inverter (GT2.8-AU Model Shown)

2

Installation

Chapter 2, “Installation”, provides information about planning for and installing the GT Inverter. It contains information to help you plan wire routes, ensure your PV array provides necessary power, and find a suitable location for installation.

The topics in this chapter are organized as follows:

- “Installation Options” on page 2–2
- “Planning the Installation” on page 2–2
- “Preparing for the Installation” on page 2–8
- “Mounting the Inverter” on page 2–9.

Installation Options

The GT Inverter may be installed as a single inverter for a single PV array of up to two PV strings (up to three PV strings for the GT5.0-AU model), or in a multiple inverter configuration for multiple PV arrays (see Figure 2-1 for diagrams of both options).

Single Inverter Installation

In this configuration, a single inverter collects the harvested solar energy and routes the power to the main utility service panel and the utility grid.

Multiple Inverter Installations

If multiple inverters are used, each inverter must be wired to an independent PV array. In this configuration, each inverter collects the harvested solar energy from a separate PV array and routes the power to the main utility service panel and the utility grid.

Communications between inverters is optional, but can be enabled by installing communications cabling to the inverter RJ45 ports. See “Connecting Network Cable between Inverters” on page 3–14.

Planning the Installation

The following issues need to be considered when planning for an installation using the GT Inverter. See the specified sections for more information.

- “Inverter Location” on page 2–4
- “PV Array Requirements” on page 2–5
- “Grounding Requirements” on page 2–7
- “Routing the Wires” on page 2–8.

Ensure that you have obtained all permits required by local authorities or utilities before commencing installation.

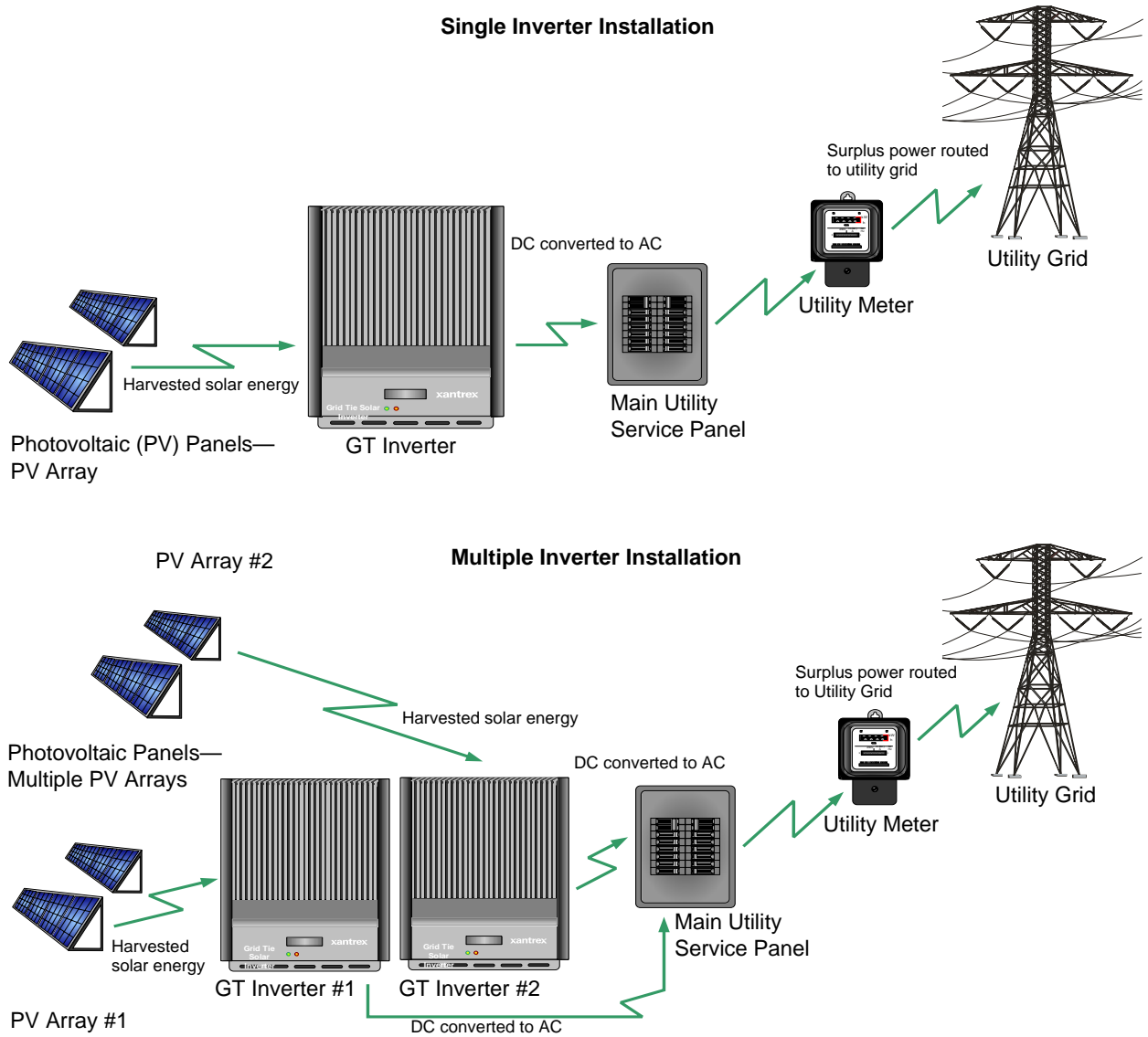

Figure 2-1 Installation Options Overview

Inverter Location



WARNING: Burn hazard

Do not install in normal traffic areas or other locations where people can accidentally come into contact with the front of the inverter. High temperatures can be present on the face of the inverter that can cause skin burns if accidentally touched..

Inverter failure due to improper installation will void the inverter warranty. Consider the following when determining where to install the inverter.

- | | |
|-----------------------------|---|
| Fire Safety | <ul style="list-style-type: none">• Do not install <i>anywhere</i> near combustible or flammable materials such as stored fuels and solvents. |
| Indoor/
Outdoor | <ul style="list-style-type: none">• The GT Inverter can be mounted indoors or outdoors.• In outdoor installations the GT Inverter is rated for exposure to rain and snow, but it should be located away from lawn sprinklers and other sources of spray. |
| Orientation | <ul style="list-style-type: none">• The GT Inverter must be mounted vertically (with DC and AC connectors facing down) on a wall or pole. See Figure 2-2. |
| Temperature | <ul style="list-style-type: none">• Ensure that the GT Inverter is mounted in a location where the ambient temperature range is -25 to 65 °C.• At extreme cold temperatures, the front panel LCD may not function normally. At higher temperatures, the unit may derate power. See “Environmental Specifications” on page A-5 and “Output Power vs. Ambient Temperature (GT2.8-AU)” on page A-4. |
| Ground
Clearance | <ul style="list-style-type: none">• Outdoors, the GT Inverter requires at least 100 cm of clearance between the bottom of the unit and the ground. This clearance helps prevent water from splashing onto the bottom of the unit.• Install the GT Inverter at a height at which the LCD is easily readable. |
| Distance | <ul style="list-style-type: none">• To minimize power losses in wiring, ensure that wire lengths between the PV array and the GT Inverter and between the inverter and the Main Utility Service Panel are kept to a minimum.• Maximum distances will depend on wire gauges used and PV array output voltages. To minimize system failures due to AC voltage faults, Xantrex recommends sizing the AC and DC wiring to have a maximum 1 to 1.5% voltage drop. |
| Debris free | <ul style="list-style-type: none">• Excessive debris (such as dust, leaves, and cobwebs) can accumulate on the unit, interfering with wiring connections and ventilation. Do not install in a location where debris can accumulate (such as under a tree). |

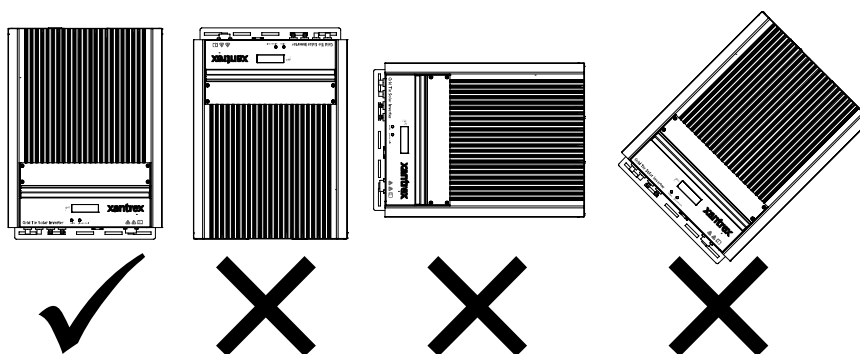

Figure 2-2 GT Inverter mounting orientation

PV Array Requirements

Equipment and Installation Recommendations

Important: The PV array should be free of shade. This requirement includes even small obstructions such as antennas, chimneys, and power lines. As well, be aware of potential obstructions from growing trees and neighboring buildings. A small amount of shade can have a disproportionately high impact on system performance.

Equipment recommendations

- *All electrical equipment should be approved for the voltage and current ratings necessary for the application.*
- All wiring should be sized correctly to minimize voltage drop.
- All exposed wires or conduits should be sunlight resistant.
- All required overcurrent protection and disconnecting means should be included in the system and accessible for maintenance.

Installation recommendations

- All electrical terminations should be fully tightened, secured, and strain relieved as appropriate.
- All mounting equipment should be installed according to the manufacturer’s specifications.
- All wires, conduit, exposed conductors and electrical boxes should be secured and supported according to code requirements.

MPPT Requirements

MPPT operational window

The MPPT software maximizes the output energy of solar arrays as long as the operating voltage is within the MPPT operational window. Ensure that the PV array used in the system operates within the MPPT operational window.

Effects of array voltages outside of the MPPT operational window are shown in Table 2-1.

Table 2-1 MPPT Operational Window (GT2.8-AU)

Voltage	Effect of Array Voltage	Inverter Mode
< 195 Vdc	Operating voltage shifts to 195 Vdc; the array is not at its maximum power point	Low power
195 to 550 Vdc	Maximum harvest of solar energy	MPPT window
550 to 600 Vdc	Reduced harvest of solar energy	Power derating
> 600	Inverter stops selling surplus energy and shuts down. Voltage above 600 Vdc may damage the inverter.	Shutdown

Table 2-2 MPPT Operational Window (GT5.0-AU)

Voltage	Effect of Array Voltage	Inverter Mode
< 240 Vdc	Operating voltage shifts to 240 Vdc; the array is not at its maximum power point	Low power
240 to 550 Vdc	Maximum harvest of solar energy	MPPT window
550 to 580 Vdc	Reduced harvest of solar energy	Power derating
> 580	Inverter stops selling surplus energy and shuts down. Voltage above 600 Vdc may damage the inverter.	Shutdown

Array Voltage and Current Limits

The solar array should be sized such that its maximum voltage output does not exceed the limits of the MPPT operational window (195/240 to 550 Vdc). See “Guidelines for Matching PV Array Size to Xantrex Grid Tie Solar Inverter Input”.



CAUTION: Equipment Damage

The array voltage must never exceed 600 V_{OC} (open circuit voltage) under any condition.

Likewise, ensure that the I_{SC} (short circuit current) rating of the array at any temperature does not exceed the short circuit current rating of the inverter.

Guidelines for Matching PV Array Size to Xantrex Grid Tie Solar Inverter Input

For determining the number of panels required in the PV string (panels connected in series), you must ensure that the following three requirements are met:

1. To avoid damage to the inverter, ensure that the PV array output will never exceed 600 Vdc under any conditions.
2. Do not exceed the maximum array short circuit-current rating marked on the inverter.

3. To achieve maximum energy harvest from your array, ensure that the V_{MP} (voltage at maximum power) does not drop below 195/240 Vdc or increase above 550 Vdc under most conditions.

Guidelines to help you meet these requirements:

- Consider the expected V_{OC} of the string under all possible conditions. The panel manufacturer provides a V_{OC} rating per panel, but it is usually rated at 25 °C. Ensure that the V_{OC} rating at the coldest ambient temperature does not exceed 600 V_{OC} . Panel voltage increases in cold temperatures—the panel manufacturer should be able to provide a coefficient of voltage increase per degree.
- Panel voltage decreases in high temperatures. This will affect the panels' V_{MP} . Again, the manufacturer's coefficient must be used with the highest expected temperature to determine the minimum V_{MP} .

Once you know the specifications of your panels, all these factors will help determine the maximum and minimum number of panels that can be used.

Visit the **Support** page at www.xantrex.com to use an online PV array sizing tool.

Grounding Requirements



WARNING: Shock hazard

The GT Inverter must be grounded in accordance with the following and with all applicable codes.

AC Grounding

AC system grounding is governed by local codes. The GT2.8-AU and GT5.0-AU inverters will function properly in AC systems with a grounded neutral or with two ungrounded lines. The GT Inverter must be provided with an equipment grounding conductor connected to the grounding terminal on the AC output connector (GT2.8-AU) or in the wiring compartment (GT5.0-AU) and routed to the ground bus of the AC load panel to which the inverter is connected.

DC Grounding

The GT Inverter is designed to work with ungrounded PV systems (neither the PV+ nor the PV– are connected to earth). The array frames and other PV equipment must have equipment grounding connections as required by applicable codes.

Lightning Protection

Reduce the risk of lightning damage by using a single-point grounding system. In this system, all ground lines terminate at the same point. This point normally is the main utility ground installed by the utility company to provide a ground for the house wiring. This ground usually consists of a copper rod driven 1.5 to 2.5 meters into the earth.

Routing the Wires

Typical configurations

Determine all wire routes to and from the GT Inverter. Typical routing configurations include:

- AC wiring from the GT Inverter to the main utility service panel
- DC input wiring from the PV array to the GT Inverter

Preparing for the Installation



WARNING: Shock hazard

Whenever a PV array is exposed to sunlight, a shock hazard exists at the output wires or exposed terminals. To reduce the risk of shock during installation, cover the array with an opaque (dark) material before making any connections and open any and all external disconnect switches between the array and the inverter. The PV modules, wiring, and other equipment must be installed in accordance with the manufacturer's instructions and all applicable installation codes.

Important: Ensure your local utility is consulted for any requirements for connecting to or returning power to the grid. Obtain all permits necessary to complete the installation. Consult your local and national electrical codes for more information.

Important: In this manual *wiring* and *wires* are used in reference to both AC and DC wiring/cabling and wires/cables.

Wiring

Wire size and length will be determined by the location of each component and their relative distance to each other. Wire sizes may also be affected by whether or not conduit is used, in accordance with wire size tables in applicable codes.

Important: Wire size should be based on the maximum power rating of the inverter. Ensure that wiring is not undersized. Undersized wiring can result in significant power losses and reduction in system efficiency.

AC Circuit Breaker Requirements

The main utility service panel must dedicate a single-pole (in the Active line) or double-pole breaker for each inverter installed. This breaker must be capable of handling the rated maximum output voltage and current of the inverter (see “Electrical Specifications” on page A-2).

AC and DC Disconnects

Depending on the installation, external AC and/or DC disconnects may be required, and they may need to be in a location easily accessible to utility or fire personnel. Consult local codes and authorities for additional information.

Mounting the Inverter

Overview



WARNING: Fire, shock and energy hazards

Before installing the GT Inverter, read all instructions and cautionary markings located in this manual, on the inverter, on the PV array, and on the main service panel.

General installation steps

Installing of the GT Inverter includes these main steps:

1. Mounting the GT Inverter (this chapter)
2. Making the DC connections from the PV array to the GT Inverter (“Connecting the DC Wiring” on page 3-2)
3. Making the AC connections from the GT Inverter to the main utility service panel (“Connecting the AC Wiring” on page 3-7)

Figure 2-3 summarizes these steps.

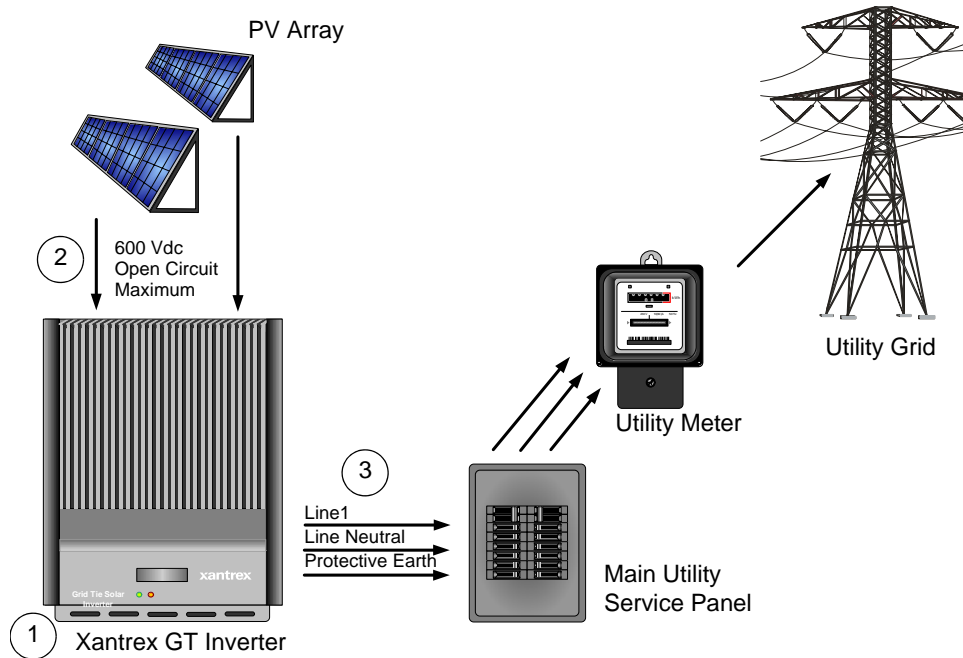

Figure 2-3 Installation Overview

This chapter describes the first step: mounting the inverter and installing accessories.

Mounting steps

Instructions for mounting the GT Inverter are described in the following sections:

- “Installing the Mounting Bracket” on page 2–12
- “Mounting the Inverter on the Bracket” on page 2–16.

Tools and Materials Needed

- Assorted screwdrivers, drill, etc.
- Level
- Mounting support material, such as plywood or poles
- Wood screws, anchors for screws, depending on mounting surface.

Dimensions

The dimensions of the inverter are shown in Figure 2-4.

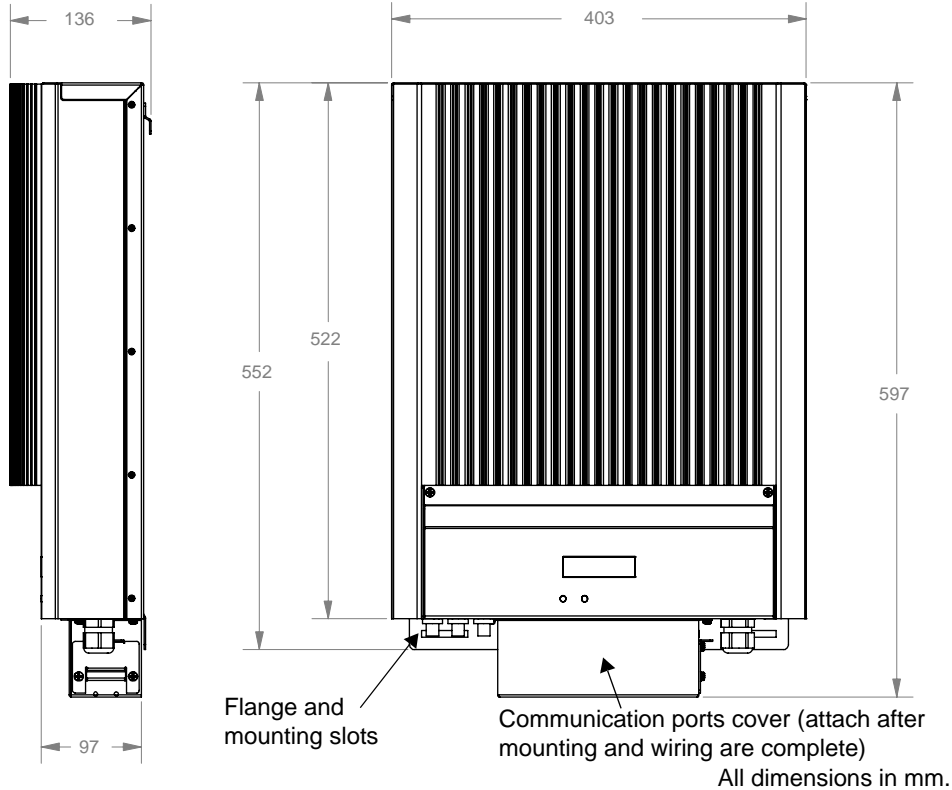

Figure 2-4 GT Inverter Dimensions (GT5.0-AU shown)



CAUTION

For the inverter to meet regulatory requirements and for weather protection, the communication ports cover must be installed.

Installing the Mounting Bracket

The mounting bracket for the GT Inverter allows the unit to be easily mounted and removed for servicing. It has one hook that matches a corresponding hook on the back side of the inverter.

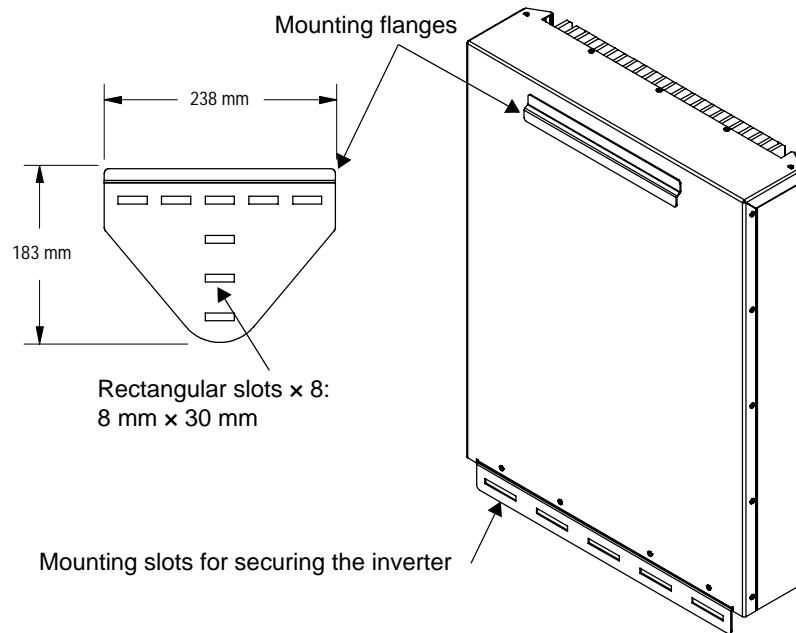

Figure 2-5 Mounting Bracket and GT Inverter

Clearance Requirements

For optimal and safe operation, make sure there is adequate clearance around the inverter. If clearances are less than these recommendations are used, additional power reduction may occur at high ambient temperatures.

Table 2-3 Inverter Clearance Requirements

Location	Minimum Clearance
Above	30 cm
Below:	Outdoors:
• Inverter	• 100 cm
• Bracket	• 130 cm
	Indoors: the same clearances are recommended but not required.
In front	Sufficient room to allow for easy access to read the display and to prevent accidental contact with hot surface.
On sides	Units can be mounted side by side with no clearance between them, but 15 cm of clearance around the outermost two units is recommended. In hot climates, some clearance between units may be needed to prevent thermal derating.

**WARNING: Shock hazard**

Before drilling holes to mount the GT Inverter, ensure there are no electrical wires or plumbing in this area.

**WARNING: Personal injury**

The GT Inverter weighs approximately 20 kg. Always use proper lifting techniques during installation to prevent personal injury.

**WARNING: Explosion hazard**

Do not store combustible or flammable materials *anywhere* near the inverter.

Surfaces for Mounting

The GT Inverter weighs approximately 20 kg. The supporting surface must be strong enough to handle 75 kg. If the supporting surface is not strong enough to handle that weight, then supporting material such as a sheet of plywood can be used to enhance the strength of the mounting surface.

The GT Inverter can be mounted to a vertical surface such as wallboard, wood siding, brick, concrete wall or pole assembly.

Mounting to
concrete surface

- If mounting the unit on a concrete surface using anchors with no supporting material, use four screws and anchors, instead of two, to adequately secure the unit and distribute the weight.

Mounting on poles
or rails

- See “Mounting on Poles or Rails” on page 2–14. Ensure the bottom of the unit is a minimum of 100 cm from the ground if mounted outdoors.

Mounting to
wallboard with
support

- Installation onto wallboard requires either the use of a supporting material such as plywood or securing the mounting screws to supporting wall studs. Use at least two screws and anchors to secure the unit to the supporting material.

Mounting to siding
using wall studs

- If mounting to exterior siding using a wall stud for support, the plywood backing will not be needed. Use at least two lag screws to secure the unit to the supporting material. Ensure the screws enter the stud at least 40 mm to adequately support the weight of the unit. After securing the bracket, the screws or bolts and washers should protrude no more than 6 mm from the bracket surface.

Important: Other than the mounting bracket, no mounting hardware is supplied with the GT Inverter. It is recommended to use 6 mm diameter fasteners. However, because mounting surfaces can vary, installers must select appropriate hardware for each installation.

Important: Local codes may impose additional mounting requirements in earthquake or other high-risk areas.

Mounting on Poles or Rails

To mount the unit using poles:

1. Ensure that poles or rails are securely assembled in place. If using horizontal rails, two rails are required: one for the mounting bracket and another for securing the bottom edge of the inverter (see Figure 2-6).
2. Connect the mounting bracket vertically to the pole or rail:
 - Be sure to use at least two bolts to secure the bracket to the support.
 - Position the lower edge of the bracket a minimum of 130 cm above the floor or ground.
 - Position the top edge of the bracket a minimum of 34 cm below any ceiling or roof.
3. If using a single vertical pole, ensure that the inverter is secure and unable to rotate around the pole.

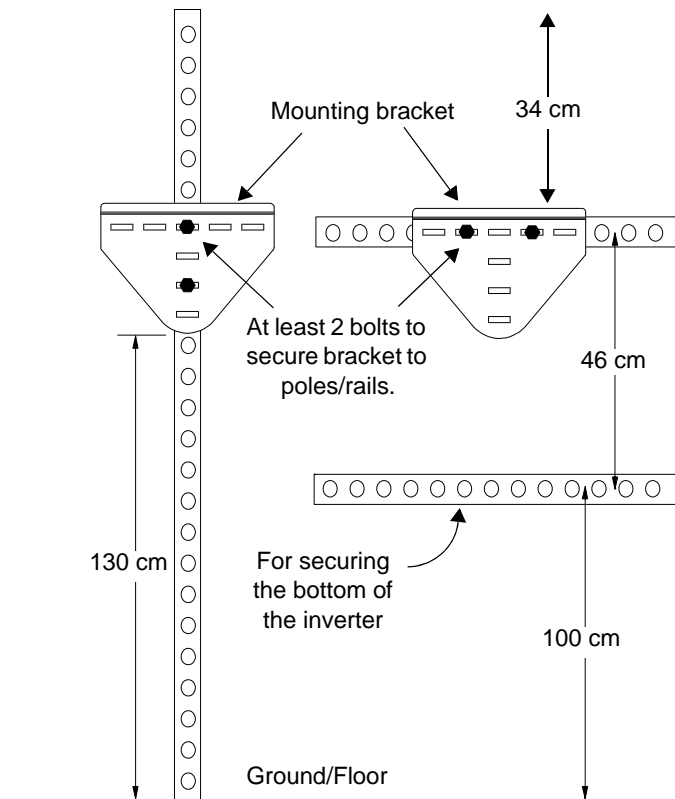

Figure 2-6 Examples of Mounting on a Pole or Rails

Mounting on Wallboard, Brick or Concrete

To mount the GT Inverter to wallboard, brick, or concrete:

1. Locate the area where the GT Inverter is to be installed.
2. Install backing support material if required.

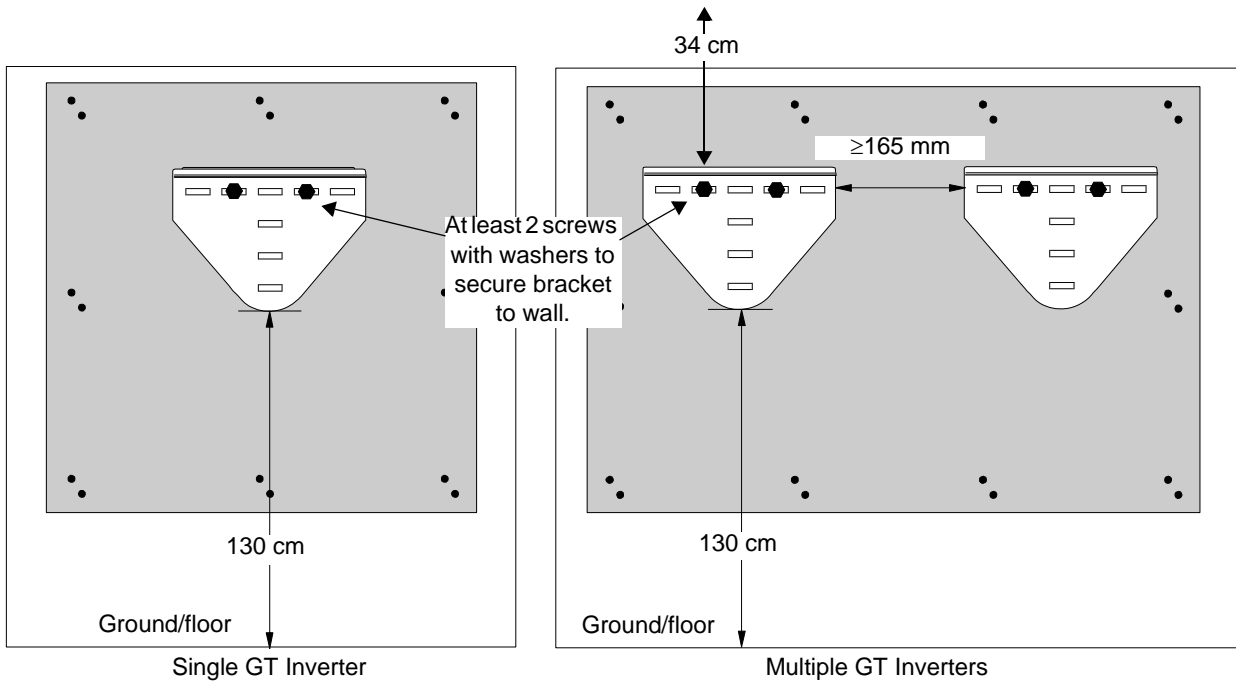

Figure 2-7 Installing the Mounting Bracket using Plywood Support

3. Using a level, place the mounting bracket against the wall surface so that the bottom edge of the bracket is at least 130 cm above the ground. Position the top edge of the bracket a minimum of 34 cm below any ceiling or roof. See Figure 2-7.
4. Mark the location for mounting screws if using a wall stud for support. At least four mounting screws and anchors are needed for concrete installations or wallboard installations where no wall studs are available for support.
5. Remove the bracket and drill appropriately sized screw or anchor holes using a drill bit.
6. Secure the bracket to the supporting surface using at least two screws and washers.

Mounting the Inverter on the Bracket

Before mounting the inverter, remove the communication ports cover (if it has been attached to the unit). With the cover removed, you can access all the mounting slots along the bottom flange. Ensure the communication ports cover is installed after mounting and wiring are completed.

Mounting a Single Inverter

To mount the inverter on the mounting bracket:

1. Place the GT Inverter's mounting hook, located on the back of the enclosure, over the bracket and ensure the inverter is seated properly, as shown in Figure 2-8.
2. After the unit is correctly seated on the bracket hook, locate the mounting slots at the bottom of the unit, and mark the location on the wall for securing screws.
3. Remove the inverter and drill pilot holes in the wallboard, brick or concrete for the securing screws.
4. Reinstall the GT Inverter on the bracket and secure the bottom of the unit with appropriate screws or anchors, and tighten.

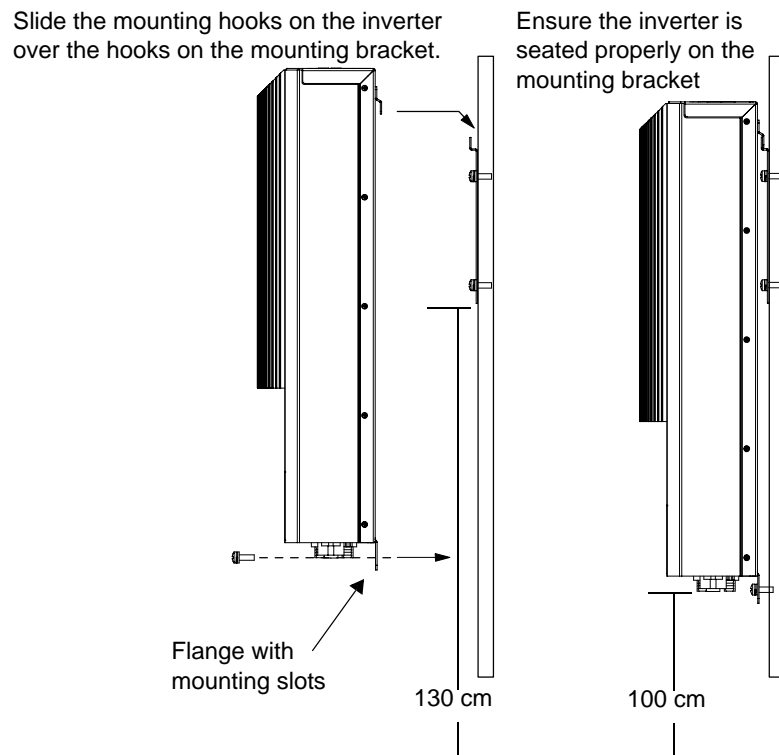

Figure 2-8 Proper Placement of the Inverter on the Mounting Bracket

3

Wiring the Inverter

Chapter 3, “Wiring the Inverter”, provides procedures for making DC and AC wiring connections for single and multiple inverter installations. This chapter also includes information about communications wiring and using GT-View monitoring software.

The topics in this chapter are organized as follows:

- “Connecting the DC Wiring” on page 3–2
- “Connecting the AC Wiring” on page 3–7
- “Connecting Multiple Inverters” on page 3–6
- “Communications Wiring for Multiple Inverters” on page 3–10

Connecting the DC Wiring

The GT Inverter is equipped with four PV quick connects (two positive, two negative) for connecting up to two PV strings. The GT5.0-AU model has six PV quick connects for connecting up to three PV strings.

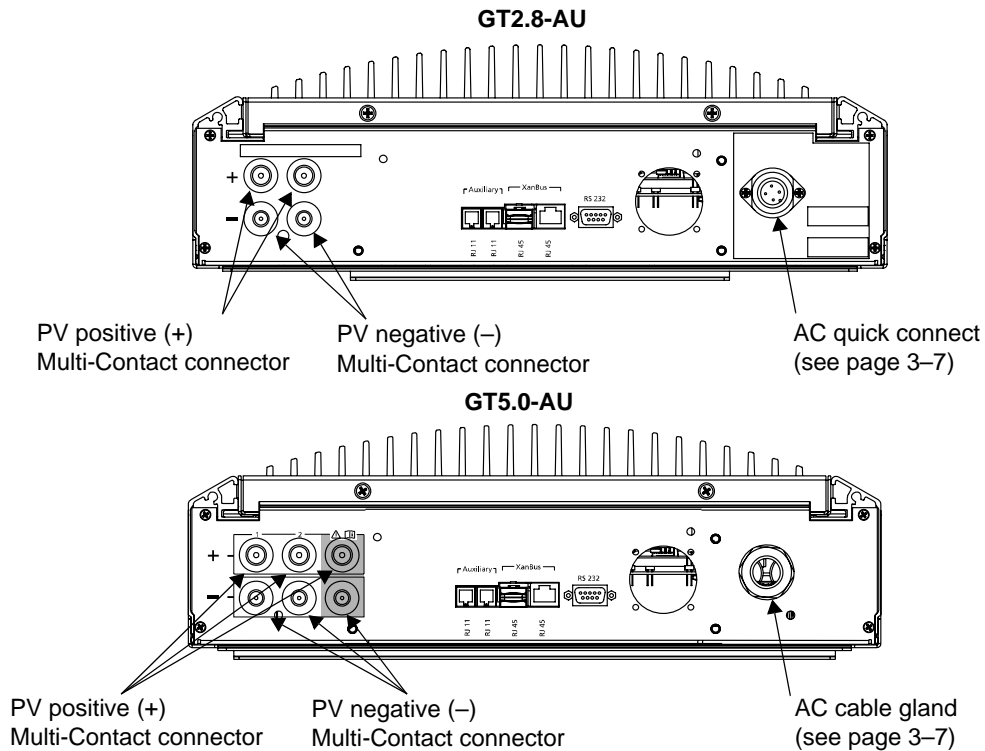

Figure 3-1 PV Quick Connect Locations



WARNING: Shock hazard

Whenever a PV array is exposed to sunlight, a shock hazard exists at the output wires or exposed terminals. Cover the PV arrays with opaque material before commencing any wiring and open all disconnect switches between the array and the inverter.



WARNING: Shock hazard

Before wiring the GT Inverter, ensure the **main breaker** in the primary utility breaker box is switched OFF. Switch this breaker ON only after all wiring is completed as instructed in the procedures.



WARNING: Fire hazard

For the GT5.0-AU model, if three PV strings are connected, internal DC fuses must be installed and the two positive internal DC wires must be relocated from their factory-installed connection points to connection points in line with the DC fuse clips. The third positive DC wire must remain connected in line with the DC fuse clip as it came from the factory. See Figure 3-2. Without proper fusing, a fire hazard can exist if a short-circuit condition occurs in one PV string.



CAUTION: Equipment damage

Improper wiring may cause permanent damage to the GT Inverter. Take special care to ensure the positive (+) and negative (-) wires from a single array connect to the same inverter.

Equipment Needed

- Conduit for wire runs and appropriate fittings/bushings (outdoor rated if the inverter is installed outdoors)
- Wire cutters/wire crimpers/wire strippers
- Digital voltmeter
- Frequency counter (optional, for troubleshooting)
- Female and male DC cable connectors to mate with the Multi-Contact connectors PV-ADSP3/GWD (positive) and PV-ADBP3/GWD (negative) on the GT Inverter. You will need two connectors (one female and one male) for each PV string.

DC Fuses (GT5.0-AU Model Only for Three PV Strings)

The GT5.0-AU has three sets of PV input connectors, allowing three PV strings to be connected to the inverter. The GT5.0-AU has an internal fused combiner that must be set up properly if three strings will be connected. The inverter's DC interconnect board has three fuse clips for DC fuses to provide additional overcurrent protection. DC fuses must be installed when connecting a third PV string to the unit. The fuses must be approved (to applicable local or national standards) 10 × 38 mm fuses rated for 600 Vdc or over, with an ambient temperature rating of 40 °C. You can also use higher rated fuses, derated for your installation's ambient temperature at full power, but with this approach larger gauge PV wiring must be used in accordance with applicable codes.

The maximum total input current is 24 A. The maximum current allowed per string (that is, for any single PV input) for the GT5.0-AU model is 15 A, whether a fuse is used or not. When calculating fuse size, do not exceed the rated maximum input current or the maximum current per string, and obey all applicable wiring codes regarding coordination of the fuse size with the PV wire size used. Using the same fuse value in each string is recommended.

Table 3-1 Recommended Fuses

Manufacturer	Model
SIBA	5019906.4, 5019906.6, 5019906.8, 5019906.10, 5019906.12
Littelfuse	KLKD 001., KLKD 01.5, KLKD 002., KLKD 02.5, KLKD 003., KLKD 03.5, KLKD 004., KLKD 005., KLKD 006., KLKD 007., KLKD 008., KLKD 009., KLKD 010., KLKD 012., KLKD 015.
Ferraz Shawmut	DCT5-2, DCT8-2, DCT10-2, DCT12-2, DCT15-2
Bussmann	FWC-6A10F, FWC-8A10F, FWC-10A10F, FWC-12A10F



WARNING

Make sure all PV and AC wiring is disconnected from the inverter before accessing or replacing the fuses or making the following wiring changes.

When installing the DC fuses, the two positive PV wires must be relocated from their factory-installed connection points to the connection points in line with the DC fuse clips. See Figure 3-2.

The DC interconnect board is inside the GT Inverter wiring compartment. To access the wiring compartment, remove the inverter front panel. It is held in place by four screws—two along the bottom and two on the front of the inverter.

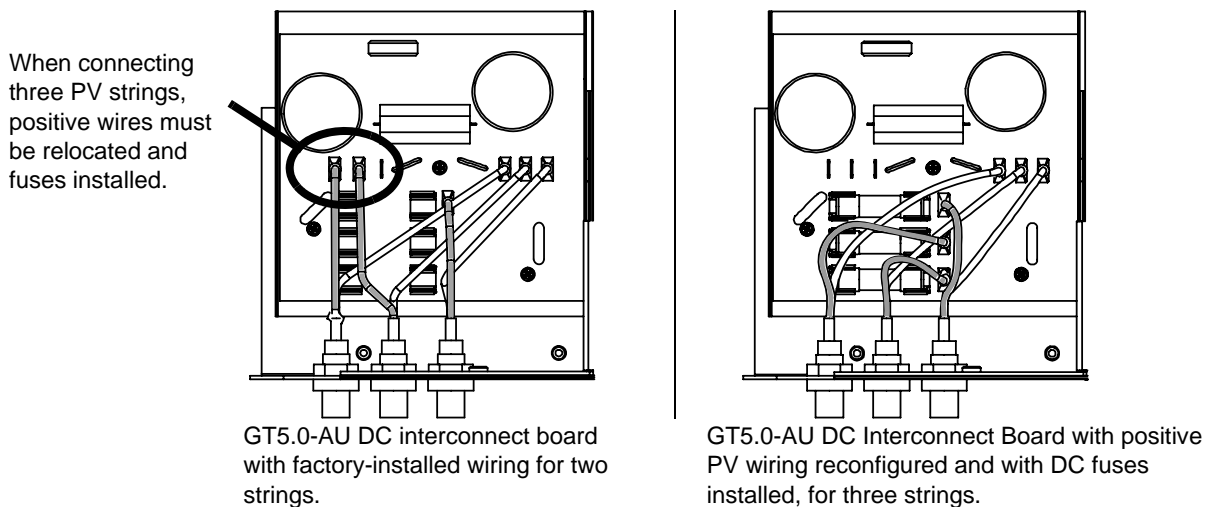

Figure 3-2 GT5.0-AU DC Fuse Installation

Connecting the PV Array

The following procedure is illustrated in Figure 3-3. If there will be more than one PV string, label the positive and negative wire pairs appropriately (for example: PV 1, PV 2).

GT5.0-AU models are factory configured to accept two PV strings. To connect a third PV string, relocate the two positive internal DC wires from their factory-installed connection points to connection points in line with the DC fuse clips, and install DC fuses as specified in “DC Fuses (GT5.0-AU Model Only for Three PV Strings)” on page 3–3. See Figure 3-2.

To wire the PV array to the GT Inverter:

1. If necessary, install DC conduit from the PV string(s) to the GT Inverter.
2. Terminate the wires coming from the PV string(s) with appropriate Multi-Contact connectors.



CAUTION: Equipment damage

Before connecting the PV array to the inverter, check to ensure correct polarity and that the voltage between the positive (+) and negative (-) terminals is below 600 Vdc ($U_{PV} \leq 600 \text{ Vdc}$).

To check the PV array DC voltage:

1. Uncover the PV arrays and expose them to full sunlight. The sunlight must be intense enough to produce the required output voltage.
2. Measure the PV array open circuit DC voltage across the DC positive (+) and negative (-) terminals of the string combiner. This voltage must be less than 600 Vdc. Voltage over 600 Vdc will damage the inverter.
3. Cover the PV arrays with an opaque material again.

3. Connect the POSITIVE (+) wire from the #1 PV string to a GT Inverter PV positive (+) quick connect.
4. Connect the NEGATIVE (-) wire from the #1 PV string to a GT Inverter PV negative (-) quick connect.
5. If necessary, repeat for the #2 or (for GT5.0-AU) #3 PV string. Double check that the wires are in the proper locations.

If only one PV string connection is used, cover the unused PV quick connects with the seals provided.

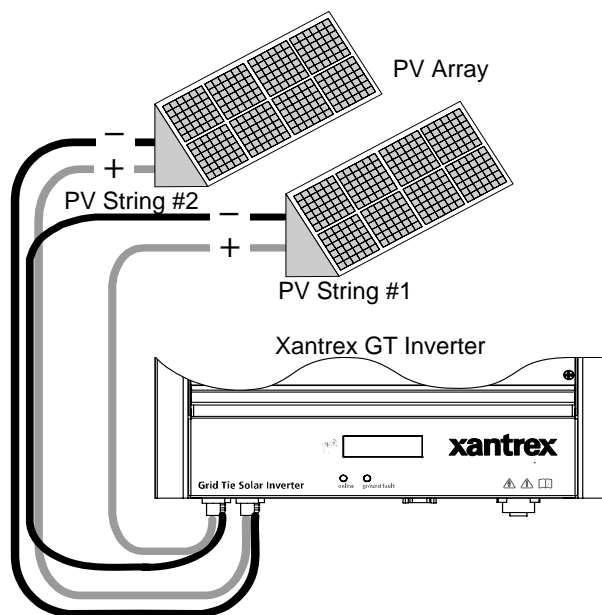

Figure 3-3 DC Connections for a Two-String PV Array

Important: Depending upon installation and local codes, fusing and/or a combiner box may be required. The installer must provide this equipment.

Connecting Multiple Inverters

For installations with multiple inverters, a separate PV array is required for each GT Inverter unit. The output of each GT Inverter feeds a separate single-pole (in the Active line) or double-pole circuit breaker in the main utility service panel.

When connecting multiple inverters, complete the wiring and perform the commissioning procedure for each inverter one at a time. For wiring instructions, see “Connecting the DC Wiring” on page 3–2 and “Connecting the AC Wiring” on page 3–7. For the commissioning procedure, see page 4–2.



WARNING: Shock hazard and equipment failure

In multiple inverter installations, it is very important to ensure each inverter is correctly connected to its own PV array(s) and that no wires are crossed. For example, connect PV1 positive (+) and PV1 negative (–) to inverter 1 and PV2 positive (+) and PV2 negative (–) to inverter 2.

Do not connect PV1 positive (+) and PV2 negative (–) to inverter 1 and PV2 positive (+) and PV1 negative (–) to inverter 2. As shown in Figure 3-4, this configuration can cause short circuit failures in the inverters and may also generate hazardous voltages within the system.

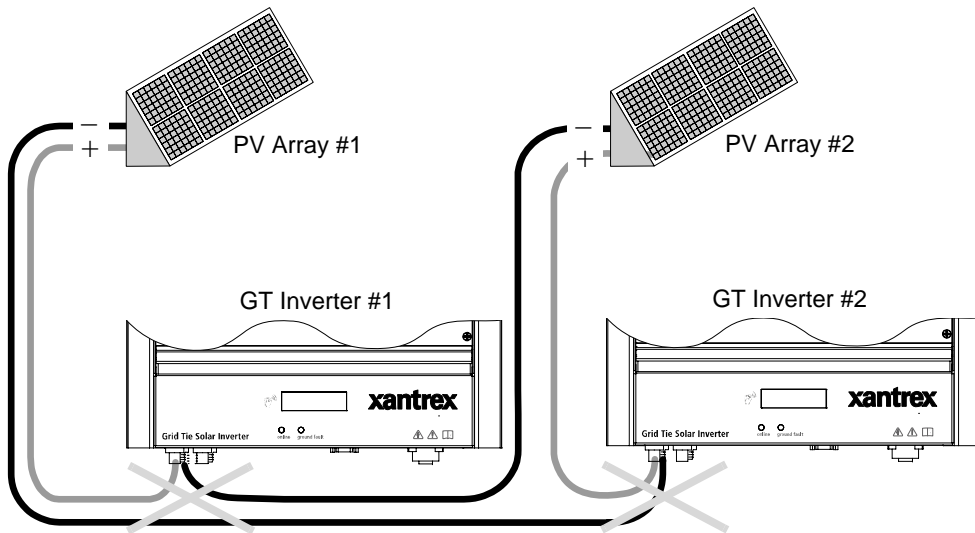

Figure 3-4 Improper Multiple Inverter Connections

Connecting the AC Wiring



WARNING: Shock hazard

Before wiring the AC connections between the GT Inverter and the AC breaker panel, ensure the **main breaker** in the breaker panel is switched OFF, and that PV power is disconnected from the inverter. Do not reapply AC or PV power until after all wiring is completed, as part of the commissioning procedure in Chapter 4, “Starting the Inverter”.

The GT Inverter can be connected to a single bi-directional meter, or to dual meters, where one meter indicates power used and the second meter indicates power sold (power supplied back to the utility). Consult the local utility to determine the proper components to install, and obtain any permits required prior to installation.

Making AC Connections for the GT2.8-AU Model

GT Inverter model 2.8-AU is equipped with a quick connect for making AC connections. You must install a mating connector on the the wiring between the utility panel and the GT Inverter. The GT Inverter must be connected to the utility with three wires—two lines (one Active phase and one neutral phase) and one protective earth (ground). Wiring must meet all code requirements and be a minimum of 2.5 mm². The recommended Binder connector will accept cables with an outside diameter of 10-12 mm and a maximum 2.5 mm² wire size.

You will need:

- Wire strippers
- Small (3 mm) slot-head screwdriver
- Binder, Series 693, Female Cable Connector, Part Number 99-4222-14-04

The AC wiring from the utility panel must be terminated with a Binder Female cable connector (Binder Series 693 part number 99-4222-14-04) before being connected to the AC quick connect on the GT Inverter.

To terminate the AC wiring:

1. Strip 10 mm of insulation from each of the wires from the utility panel.
2. Unscrew the female terminal from the shell of the female cable connector. See Figure 3-5.
3. Unscrew the other components of the female cable connector.
4. Run the wires through the pressing screw, pinch ring, seal, and shell of the female cable connector.
5. On the female terminal, connect the protective earth wire to the terminal marked with the \oplus symbol. See Figure 3-6.
6. Connect the neutral conductor to the terminal marked with 1.

7. Connect the Active conductor to the terminal marked with 2.
Terminal 3 is not used.
8. After ensuring all the wires are tightened in their terminals, screw the shell onto the female terminal.
9. Replace the remaining components of the female cable connector, ensuring a tight seal.
10. Tighten the pressing screw.

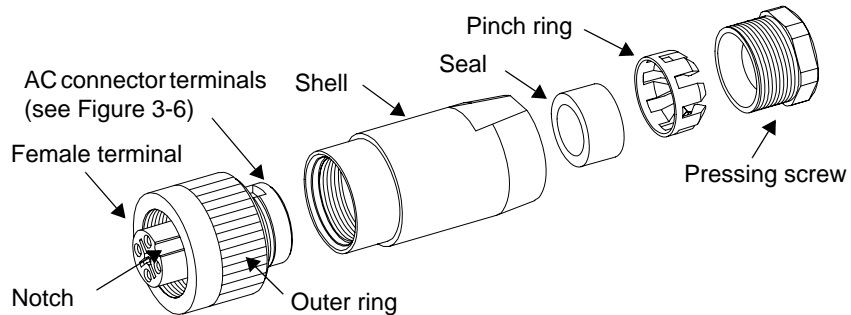

Figure 3-5 AC Connector (Female)

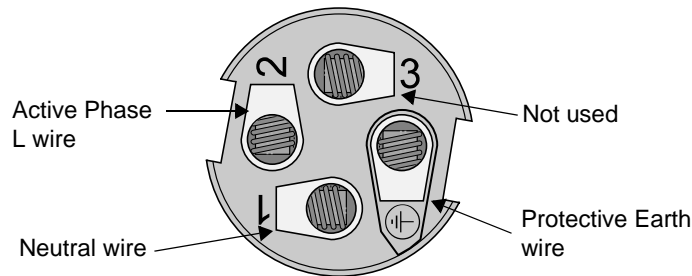

Figure 3-6 AC Connector Terminals

To connect the AC connector to the GT Inverter:

1. Line up the notch on the female AC cable connector with the connector on the GT Inverter.
2. Insert the AC cable connector into the connector on the GT Inverter.
3. Secure the connector by turning the outer ring.



CAUTION

For the inverter to meet regulatory requirements and for weather protection, the communication ports cover must be installed. If no communications wiring is required, install the communication ports cover when all DC and AC connections are complete (see Figure 3-12). If communications wiring is required, install the cover after completing the communications wiring (see “Communications Wiring for Multiple Inverters” on page 3-10 or “Communications Wiring for Monitoring a Single Inverter” on page 3-16).

Making AC Connections for GT5.0-AU Model

AC wiring to the GT5.0-AU model is connected directly to the AC terminal block, and then secured with the supplied cable gland. The GT Inverter must be connected to the utility with three wires—two lines (one Active phase and one neutral phase) and one protective earth (ground). The internal wiring block will accept wires sizes 6 mm^2 - 16 mm^2 . The supplied gland will accept cables with an outside diameter of 11-17 mm. If your cable has an outside diameter out of this range (or if you wish to use an alternate entry point), remove the supplied gland and replace it with a suitably-sized one. If you use an alternate entry port you must remove the existing gland assembly and plug the hole with an approved blanking plate.

You will need:

- Wire strippers
- Slot-head screwdriver

To connect the AC wiring:

1. Strip 10 mm of insulation from each of the wires from the utility panel.
2. Remove the inverter front panel. It is held in place by four screws—two along the bottom and two on the front.

The wiring compartment is behind the front panel.

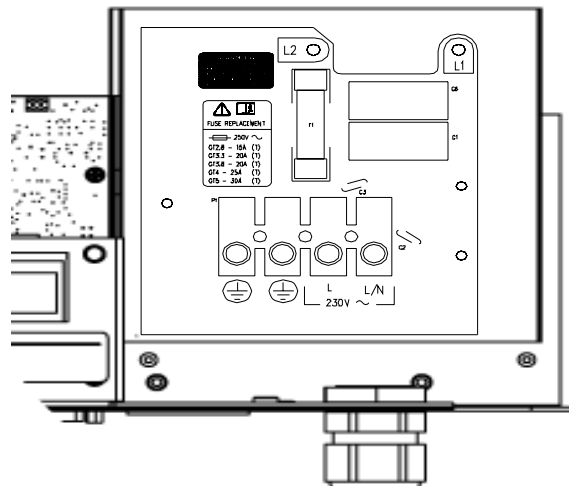

Figure 3-7 GT5.0-AU AC Wiring Compartment and Terminal Block

3. Loosen, but do not remove, the AC cable gland cap nut.
4. Pass the three wires from the utility panel through the cable gland and into the wiring compartment.

5. Loosen the appropriate terminals and insert the wires into the terminals.
 - a) Connect the protective earth wire to a terminal marked \perp .
 - b) Connect the neutral phase wire to the terminal marked L/N. (On older boards this rightmost AC terminal is marked with ~.)
 - c) Connect the Active phase L wire to the terminal marked L. (On older boards this left AC terminal is marked with ~.)
6. Tighten the terminals to a torque of 1.45 to 1.55 Nm (12.84 to 13.71 lbf-in).
7. Allowing the wires an appropriate amount of slack within the wiring compartment, tighten the cable gland cap nut to a torque of 4 Nm, creating a tight seal.
8. Re-attach the inverter front panel.



CAUTION

For the inverter to meet regulatory requirements and for weather protection, the communication ports cover must be installed. If no communications wiring is required, install the communication ports cover when all DC and AC connections are complete (see Figure 3-12).

Communications Wiring for Multiple Inverters

Communications wiring between multiple GT Inverters allows information about each inverter and its associated PV array to be communicated between all of the inverters in the system. Information about the entire system can be displayed on any inverter LCD in the system.

For example, in a two-inverter system, if inverter #1 is producing 1500 W and inverter #2 is producing 2000 W, both inverters display a total system power of 3500 W. The cumulative energy produced by both inverters that day is also displayed.

You can still view information for an individual inverter in a system. See “To view unit-specific screens in a multiple unit system:” on page 5–6.

Without communications wiring, each inverter in a system displays information only for the unit and its associated PV array.

Xanbus Network Technology

GT Inverters are Xanbus-enabled devices. They use Xanbus (a communications protocol developed by Xantrex) to communicate with other GT Inverters. Each GT Inverter is connected by an CAT5 cable, as shown in Figure 3-8.

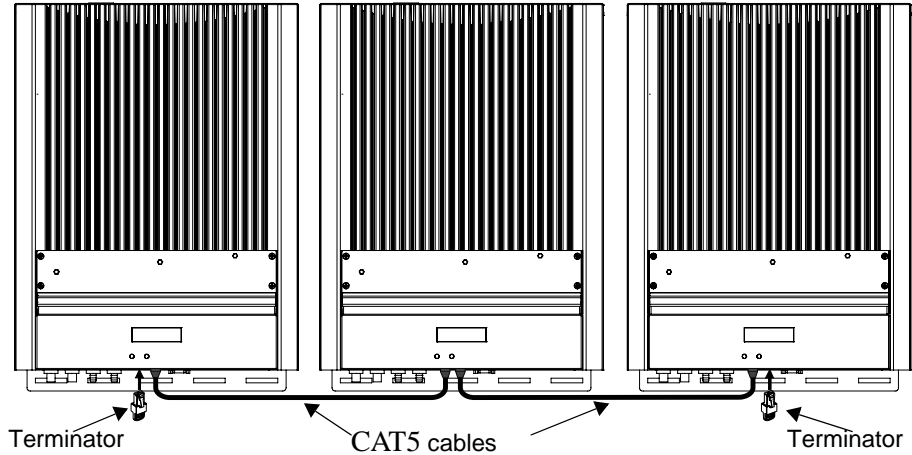

Figure 3-8 Network Layout (Communication Ports Cover Not Installed)



CAUTION: Equipment damage

Connect only Xanbus-enabled devices.

Although the cabling and connectors used in this network system are the same as Ethernet connectors, **this network is not an Ethernet system**. Equipment damage may result from attempting to connect Xanbus to different systems.

Table 3-2 provides information on maximum Xanbus network length.

Table 3-2 Total Xanbus Network Length

Xanbus Baud Rate	Total Xanbus Network Length
250 kbps	40 m (130 ft)
125 kbps	300 m (1000 ft)

Important: Xanbus baud rate is set to 250 kbps by default. If you want to switch to 125 kbps, make sure to follow the recommended procedure supplied by Xantrex. See the Application Note, “Xantrex Grid Tie Solar Inverter Baud Rate Change Procedure” (976-0216-01-01 available on www.xantrex.com).

Important: Remote upgrade using the Xantrex Communications Gateway is not supported on systems with a 125 kbps baud rate. If you change the baud rate to 125 kbps, then you will no longer be able to use the Gateway to upgrade the firmware on GT inverters. You will have to upgrade each inverter in the system using an RS-232 cable and a laptop.



CAUTION: Unpredictable network operation

Do not exceed the maximum total Xanbus network length shown in Table 3-2, “Total Xanbus Network Length” on page 3-11. Proper network operation cannot be guaranteed when these distances are exceeded.

Important: When creating long Xanbus networks (i.e. greater than 100 m), you must verify network integrity using a CANbus network analysis tool such as the Maretron N2KMeter Diagnostic Tool for NMEA2000 compatible networks. See “Verifying the Xanbus Network” on page 3-15.

Network Components

Terminators

Network terminators (Figure 3-9) are required at both ends of the network to ensure the communication signal quality on the network. Network terminators are inserted into a GT Inverter RJ45 (Xanbus) port. The GT Inverter comes with one network terminator pre-installed.

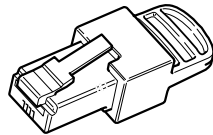

Figure 3-9 Network Terminator

GT Inverter Xanbus ports

Two RJ45 ports are provided on the GT Inverter for making network connections. See Figure 3-10 for the location of these ports.

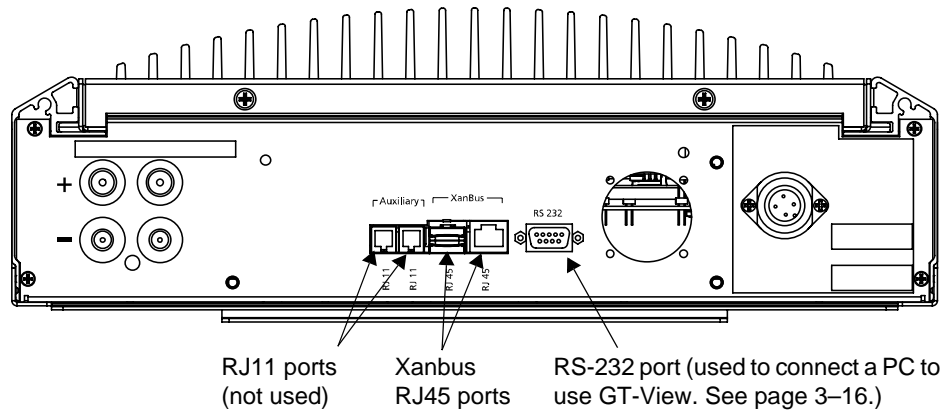

Figure 3-10 Location of Xanbus RJ45 Ports

Network cables The network uses Category 5 (CAT 5 or CAT 5e) cable, a standard Ethernet cable available from any computer supply store.



CAUTION: Equipment damage

Do not use crossover cable in a Xanbus system.

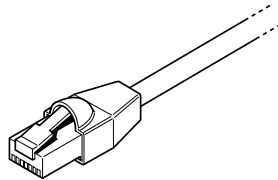

Figure 3-11 Network Cable

Purchasing Network Components

Consult your system designer to determine what network components will be needed for your specific installation. Table 3-3 provides a partial list of network components and part numbers. Pre-made cables are available in lengths from 0.9 to 22.9 metres.

Call your dealer or visit www.xantrex.com for information on purchasing network components.

Table 3-3 Network Components and Part Numbers

Network Component	Part Number
Network cable 0.9 m	809-0935
Network cable 7.6 m	809-0940
Network cable 22.9 m	809-0942

Guidelines for Routing the Network Cables



WARNING: Shock hazard

Do not route the network cables in the same conduit or panel as the AC and DC power cabling.

To ensure maximum performance of your network, follow these guidelines when routing the network cables. Route the cables before installing Xanbus-enabled devices.

- Route the cables away from sharp edges that might damage the insulation. Avoid sharp bends in the cable—no less than a 100 mm radius.
- Allow for some slack in the cable.
- Keep the alignment of wire pairs inside the sheath as straight as possible.

- Allow separation between data and power cables (data cables should only cross a power cable at right angles).
- Do not staple the cable with metal cable staples. Use the appropriate hardware fasteners to avoid damage to the cable.



CAUTION: Unpredictable device behavior

Do not connect one end of the network to the other to make a ring or loop.

Connecting Network Cable between Inverters

This procedure assumes only two inverters are installed. However, there can be up to ten inverters wired in this configuration.

To provide communication between multiple inverters:

1. Remove the communication ports covers from all inverters. See Figure 3-12.
1. Connect the network cable to an empty RJ45 port in Inverter #1.
2. Pass the cable through the cable clamp on the communication ports cover of Inverter #1.
3. Pass the cable between Inverter #1 and Inverter #2, securing the cable appropriately.
4. Pass the cable through the cable clamp on the communication ports cover of Inverter #2.
5. Connect the network cable to an empty RJ45 port in Inverter #2.
6. For more than two inverters, continue connecting cable as described above.
7. If not already installed, insert male network terminators into the empty RJ45 ports in the inverters at the beginning and end of the network.

After connecting network cables and inserting terminators, there should be no empty RJ45 ports in any connected inverter.

- After completing network cabling, tighten all cable clamps (ensuring there is adequate slack in the cable) and replace the communication ports covers on all units. See Figure 3-12.

**CAUTION**

For the inverter to meet regulatory requirements, the communication ports cover must be installed.

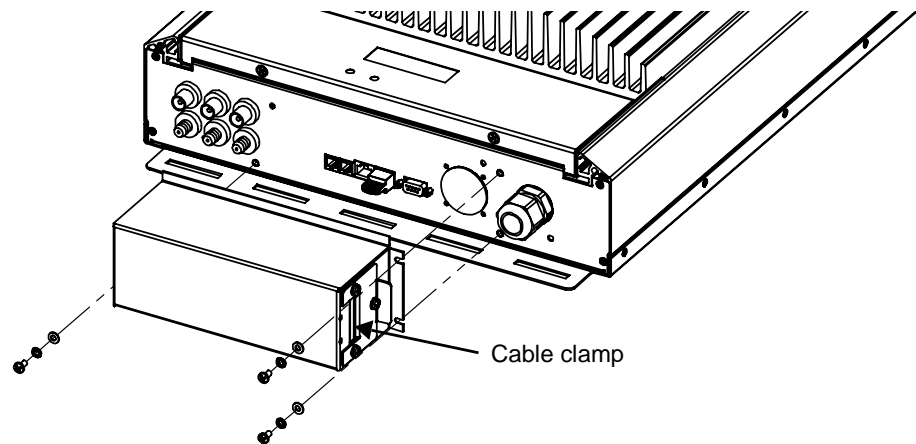

Figure 3-12 Replacing the Communication Ports Cover

Verifying the Xanbus Network

For long Xanbus networks (greater than 100 m), you must verify network integrity using a CANbus network analysis tool such as the Maretron N2KMeter Diagnostic Tool for NMEA 2000 compatible networks. To determine if the network is healthy, check to see if any bus errors are present on the network. The presence of bus errors, specifically more than one bus error per second, indicates that the network is not operating optimally.

- If the CANbus analyzer indicates your network is not operating properly, check the following and then re-test the network.
- Make sure the total Xanbus network length has not been exceeded. See Table 3-2, “Total Xanbus Network Length” on page 3-11.
- Make sure the network has only two terminators installed – one at each far end of the network.
- Make sure there are no long stub connections coming from a Xanbus 3-port T connector (if any are used). Daisy chain network configuration is the optimal configuration.
- Make sure all cable sections are correct and not shorted anywhere.

Communications Wiring for Monitoring a Single Inverter

You can view GT Inverter operational data on a personal computer using the Xantrex GT Solar Inverter Viewer (GT-View), which you can download free at www.xantrex.com.

To use GT-View, you must connect your computer's serial port to the GT Inverter RS-232 port (see Figure 3-10).

To connect your computer to the GT Inverter, you must use a serial DB9 straight through cable.

The RS-232 connector on the GT is configured as follows:

- Pin 2: transmit
- Pin 3: received
- Pin 5: ground.

All other pins are unused.

To connect a single GT Inverter to a personal computer:

1. With DC and AC power disconnected from the inverter, remove the communication port cover.
2. Plug the male end of the serial cable into the GT Inverter RS-232 port.
3. Pass the female end of the serial cable through the cable clamp on the communication port cover.
4. Replace the communication port cover.
5. Plug the female end of the serial cable into your computer's serial port. A USB to DB9 converter (not supplied) may be required.
6. Restore DC and AC power to the inverter.

When power is restored to the GT Inverter, you can run GT-View on your computer to monitor the inverter's operation.

Note: In multiple installations, GT-View monitors only the inverter to which the computer is connected. However, if the inverters are connected with a Xanbus cable, GT-View will display total system wattage and the accumulated daily energy produced by all inverters. To monitor multiple inverters, you require multiple DB9 cable connections (one per inverter) to your computer.

GT-View displays operational data such as power output in AC watts, lifetime energy produced, and inverter temperature. Data is updated every two seconds (default setting).

4

Starting the Inverter

Chapter 4, “Starting the Inverter”, contains information on starting up the Xantrex Grid Tie Solar Inverter and performing a functional test.

The topics in this chapter are organized as follows:

- “Commissioning Procedure” on page 4–2
- “Disconnect Test” on page 4–3.

Commissioning Procedure

To ensure that each GT Inverter is wired correctly, each inverter should be wired individually using the wiring procedures in Chapter 3, and turned on using this commissioning procedure. Once a single inverter has been commissioned, it should be turned off and the wiring and commissioning procedures should be performed for the next inverter. Repeat in this manner until all the inverters in the installation have been connected.

Perform this commissioning procedure step-by-step for each GT Inverter installed. Do not attempt to connect all wires to all inverters and turn on all at the same time.



CAUTION: Equipment damage

Improper wiring may cause permanent damage to the GT Inverter. Take special care to ensure the positive (+) and negative (–) wires from a single array connect to the same GT Inverter.



WARNING: Shock hazard

Hazardous voltages are present from two sources. Use extreme caution during startup procedure. Before applying power to the GT Inverter, ensure all AC and DC wiring is correct.



WARNING: Shock hazard

Ensure the protective earth (ground) wire from the inverter is connected to Earth before applying AC. Failure to do so could result in a shock hazard upon touching the enclosure. Consult the local utility for specific grounding requirements.

To start the GT Inverter:

1. Ensure the AC breaker is off.
2. Ensure the correct multi-contact PV connectors are firmly plugged into the GT Inverter as described in “Connecting the DC Wiring” on page 3–2.
3. (GT 2.8-AU only) Ensure the AC quick connect is firmly inserted into the GT Inverter and that the coupling ring is tight.
4. Uncover the PV array and/or close the main DC disconnect switch, if one is installed.
Ensure the PV array is producing the required output voltage.
5. Connect the utility grid voltage by switching the AC circuit breaker on.

6. Monitor the startup sequence on the front panel LCD.

The GT Inverter starts automatically when it receives DC voltage within the correct range and it is connected to an acceptable grid.

To monitor the startup sequence, check the GT Inverter LCD. The startup screens (see Table 5-1 on page 5-3) should appear for five seconds each, and then the *Reconnecting in sss seconds* special screen (see Table 5-10 on page 5-10) will appear until the protection timer countdown is completed.

7. Run the disconnect test.

Disconnect Test

The disconnect test is designed to verify correct operation of the Xantrex Grid Tie Solar Inverter both on initial operation and periodically through its life as required by the utilities. This test ensures that the Xantrex Grid Tie Solar Inverter does not island by sending electricity to the utility grid when the local utility has shut off the grid for repairs, or when the utility wiring is damaged.

When operation of the inverter has been verified and the unit is producing power, run the disconnect test as described in this procedure.

To run the disconnect test:

1. Switch off the AC circuit for the inverter.

This can be accomplished by switching the breaker on the main panel that feeds the inverter. The disconnect for the home or business may be used as well.

2. Have someone watch the front panel of the inverter to ensure the green light on the front of the inverter goes out.

The green light goes out when the AC circuit is switched off, disconnecting the inverter from the AC grid. The front panel display will show an AC Fault display, indicating that the AC is out of the operating range.

3. Switch on the AC circuit for the inverter.

The inverter will respond by beginning its countdown. The green light will remain off. Following the required delay after applying AC, the green light will turn on and the inverter will begin to send power to the grid. The display will then return to showing the power being produced and the total kWh produced to date.

4. If you have another GT Inverter to commission, switch off the AC circuit for the inverter you have just commissioned and tested by switching off the breaker on the main panel. You can then run the commissioning procedure and disconnect test on the next inverter.

5

Monitoring the Inverter

Chapter 5, “Monitoring the Inverter”, contains information for understanding the LCD screens and the LED indicators.

The topics in this chapter are organized as follows:

- “Monitoring the Front Panel Display” on page 5–2
- “Front Panel Display Screens and What They Mean” on page 5–3
- “Status Indicator Lights” on page 5–11.

Monitoring the Front Panel Display

During startup	During startup, the inverter’s front panel liquid crystal display (LCD, see Figure 5-1) shows the first three screens described in Table 5-1, “Startup Screens on GT5.0-AU Front Panel Display” on page 5–3.
During waiting period	When the protection timer begins, the inverter displays <i>Reconnecting in sss seconds</i> (see Table 5-10, “Special Message Screens” on page 5–10).
During operation	When the protection timer stops, the GT Inverter begins selling power, indicated by the power output reading in the display (see Table 5-2, “Normal Operation Default Screen” on page 5–5).
When the inverter is offline or there is fault condition	When the GT Inverter is offline (at night, for example) or a fault condition has been detected, the LCD shows a message screen to indicate that state. The specific fault condition will be identified. See Table 5-5, “Offline Mode Default Display” on page 5–7 and Table 5-8, “Fault Message Screens” on page 5–8.

Important: The values in the front panel LCD are not user adjustable.

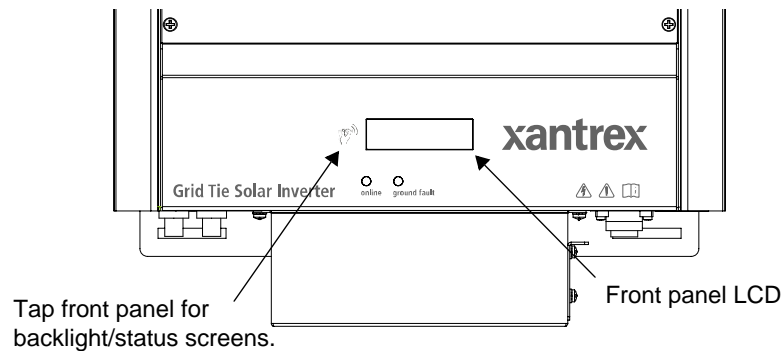

Figure 5-1 Front Panel LCD Location

Viewing more information	Additional screens of information about the performance of the GT Inverter can be displayed by tapping the inverter front panel. This causes the LCD to cycle through a series of information screens in Normal Operation, Offline or Fault modes. These are described in detail in the following section, “Front Panel Display Screens and What They Mean”.
--------------------------	--

Front Panel Display Screens and What They Mean

Important: For the tables in this section, all numbers are examples only. Your model, revision numbers, and performance data will vary.

The front panel display shows different message screens during different modes of operation (Startup, Normal, Offline, and Fault). All single units display a basic set of message screens; multiple unit systems display additional screens in Normal Operation and Offline modes.

In addition there are special message screens that may appear in any operational mode. All of these message screens are described in more detail in the following tables.

Startup Mode

During startup, the GT Inverter displays several message screens on its front panel LCD. The startup screens appear in the order shown in Table 5-1.

Table 5-1 Startup Screens on GT5.0-AU Front Panel Display

Display*	Duration	Description
Power 5000W AU-230V	5 seconds	Startup message 1: Maximum output power and Region-nominal output voltage
Flash = 03.01 ROM = 03.00	5 seconds	Startup message 2: Model and revision numbers for Flash and ROM memory on the GT Inverter. The ROM revision number applies to the protection processor.
Vh= 253V Clr t < 0.20s	3 seconds	Vh: high threshold voltage setting, the threshold at which the inverter disconnects itself from the power grid when abnormally high AC voltage is detected.† Clr t: clear time.‡
VI= 196V Clr t < 0.20s	3 seconds	VI: low threshold voltage setting, the threshold at which the inverter disconnects itself from the power grid when abnormally low AC voltage is detected. Clr t: clear time.
Vph= 0V Clr t < 0.20s	3 seconds	Vph: phase-to-neutral (rms) high threshold voltage setting. Note: Phase-to-neutral threshold voltages are disabled for Australian GT Inverter models so this screen always displays 0V. Clr t: clear time.

Table 5-1 Startup Screens on GT5.0-AU Front Panel Display

Display*	Duration	Description
Vpl= 0V Clr t < 0.20s	3 seconds	Vpl: phase-to-neutral (rms) low threshold voltage setting. Note: Phase-to-neutral threshold voltages are disabled for Australian GT Inverter models so this screen always displays 0V. Clr t: clear time.
Fh= 51.0Hz Clr t < 0.15s	3 seconds	Fh: frequency high threshold setting, the threshold at which the inverter disconnects itself from the power grid when abnormally high frequency is detected. Clr t: clear time.
Fl= 48.0Hz Clr t < 3.10s	3 seconds	Fl: frequency low threshold setting, the threshold at which the inverter disconnects itself from the power grid when abnormally low frequency is detected. Clr t: clear time.
Reconnect Delay 185.00s	3 seconds	Setting for the reconnect delay for the protection timer. After a fault clears for the specified clear time, the protection timer starts counting down before the inverter attempts to deliver power to the grid.

* All numbers in this and following tables are examples only. Your model, revision numbers, and performance data will vary.

† The voltage and frequency thresholds, clear times and reconnect delay in Table 5-1 can be adjusted for multi-unit installations producing 30 kW or more (with the permission of the local utility) using GTConfigLite software.

‡ The clear time is the total time to disconnect the output from the grid. It is the sum of the debounce time and the hardware delay time. The debounce time is the protection processor waiting time before it declares a fault. This delay is necessary to avoid nuisance trips.

The protection timer begins its countdown during startup and the *Reconnecting in sss seconds* screen appears until the timer countdown is complete.

Normal Operation Mode

The LCD on the GT Inverter is refreshed every two seconds, so all readings are current to within two seconds. There is a default display available at all times, and a series of additional screens that can be displayed by tapping the front panel to change the display.

Normal Operation default display

After the protection timer has completed its countdown and during normal operation, the GT Inverter displays the normal operation message screen shown in Table 5-2.

Table 5-2 Normal Operation Default Screen

Display	Description
System 2000W	Power being produced by the system now.
Today 9.875kWh	Cumulative energy produced by the system today.

If there is sufficient energy from the PV array, this screen is displayed continuously while the system is operating normally. In a multiple unit system connected by network cables, the power and cumulative energy values displayed are for the entire system.

During low light conditions when the GT Inverter cannot produce any power, the Normal Operation default screen flashes alternately (every two seconds) with the Insufficient Solar Energy screen (see Table 5-10, “Special Message Screens” on page 5–10).

More screens for all systems

Besides the default normal operation display, more system information messages can be viewed.

To view more Normal Operation information:

- Tap the front panel to advance the display to the next screen. Normal operation screens shown in Table 5-3 are displayed in the order given, as you tap successively on the unit. They are common to all GT Inverter systems, no matter how many units are installed.

If you continue to tap the unit, then the LCD continues to cycle through all of the available normal operation screens. Each screen is displayed for a maximum of 30 seconds. If you do not tap again during that time period, then the LCD backlight turns off and the display reverts to the default system message screen.

Table 5-3 Normal Operation Screens for All GT Inverters

Tap	Display*	Description
1st	System 2000W Today 2.500kWh	LCD backlight turns on for better readability and default Normal Operation screen is displayed.
2nd	System Lifetime 305kWh	Lifetime energy produced by the GT Inverter system.
3rd	Time Online Today hh:mm:ss	Length of time inverter has been online today, in hours (hh), minutes (mm) and seconds (ss).
4th	Array Readings 350.5V 8.4A	Immediate DC voltage and current readings from the PV array.
5th	Grid Readings 230.6V 50.0Hz	Immediate AC voltage and frequency readings from the Grid.
6th	XanBus 250Kbps Tx:OK Rx:OK	Xanbus network baud rate, transmitter and receiver status.

* In a multiple unit system with network cables properly installed, the system values displayed are for the entire system. For example, in a two-inverter system, if inverter #1 is producing 1500 W and inverter #2 is producing 2000 W, both inverters display a total system power of 3500 W. Time online and array readings are for the local inverter and PV array associated with that inverter.

Additional messages for multiple unit systems only

In addition, to the normal system message screens, additional screens specific to each GT Inverter unit can be displayed when the unit is connected with communications wiring to other GT Inverters. These screens are only available on multiple unit systems.

To view unit-specific screens in a multiple unit system:

1. Tap the front panel to advance the display to the next screen. Continue tapping until the final system message screen (*Grid Readings* in Table 5-3 above) is displayed.
2. Tap again. Normal operation screens shown in Table 5-4 are displayed in the order given, as you tap successively on the unit.

If you continue to tap the unit, then the LCD will cycle through all of the available normal operation screens. Each message is displayed for up to 30 seconds. If you do not tap again within that time period, then the LCD backlight turns off and the display reverts to the default normal operation screen (Table 5-2).

Table 5-4 Additional Normal Operation Screens for Each GT Inverter in a Multiple Unit System

Tap	Display	Description
7th	Unit 1500W Today 1.250kWh	Power being produced by this unit now. Cumulative energy produced by this unit today.
8th	Unit Lifetime 150kWh	Lifetime energy produced by this GT Inverter unit

Offline Mode

Offline default display

At night and when no power is being produced by the PV array (offline mode), the GT Inverter displays the screen shown in Table 5-5.

Table 5-5 Offline Mode Default Display

Display	Description
Inverter Offline	Displayed at all times while the system is offline.

Offline messages for all systems

Additional message screens can be viewed when the system is offline by tapping the front panel. Each additional tap displays the next screen, in the order shown in Table 5-6.

These message screens are common to all GT Inverter systems, no matter how many units are installed. If you continue to tap the unit, then the LCD will continue to cycle through all of the available offline mode screens.

Table 5-6 Offline Mode Screens for All GT Inverters

Tap	Display*	Description
1st	Inverter Offline	LCD back light turns on for better readability and default Offline Mode screen is displayed.
2nd	System 0W Today 2.50kWh	Power being produced by the system now. Cumulative energy produced by the system today.
3rd	System Lifetime 305kWh	Lifetime energy produced by the system.
4th	Time Online hh:mm:ss	Total time that the system was online today, in hours (hh), minutes (mm) and seconds (ss).

* In a multiple unit system with network cables installed, the system values displayed are for the entire system. Time online is for the local inverter.

Additional Offline messages for multiple unit systems

Multiple unit systems in offline mode display all of the message screens shown in Table 5-6, plus the additional screens shown in Table 5-7. These additional screens are displayed following the *Time Online* screen.

These screens are only displayed when multiple GT Inverters are connected by network cables. If you continue to tap the unit, then the LCD continues to cycle through all of the available offline mode screens.

Table 5-7 Additional Offline Mode Screens for Each GT Inverter in a Multiple Unit System

Tap	Display	Description
5th	Unit 0W Today 1.25kWh	Power being produced by this unit now. Cumulative energy produced by this unit today.
6th	Unit Lifetime 150kWh	Lifetime energy produced by this unit.

Fault Mode

When a fault state is detected, the appropriate fault message appears on the front panel display at the next screen refresh (i.e., within 2 seconds). The GT Inverter fault message screens are shown in Table 5-8.

Fault Mode causes

These message screens only appear when there is a fault, and then flash alternately with the Inverter Offline default screen (Table 5-5) until the fault is corrected.

Table 5-8 Fault Message Screens

Display	Description
DC Voltage Fault 145.5V	The actual DC voltage is over or under the allowable range. Self-clearing, no action required. The PV array should be configured such that DC voltage falls within the input voltage maximum power point range specified for your model in “Electrical Specifications” on page A-2.*
AC Voltage Fault 280V	The actual AC voltage is over or under the allowable range, as specified in “Electrical Specifications” on page A-2. This is a utility fault; it will clear itself when the AC voltage comes within the specified range.†
AC Current Fault	The AC output current is over the allowable limit, which is 0.5 A less than the maximum output fault current. See “Electrical Specifications” on page A-2. The message clears after 15 seconds if the output current falls below the limit.

Table 5-8 Fault Message Screens

Display	Description
Frequency Fault 47.0Hz	The actual frequency is over or under the allowable range, as specified in “Output” on page A-2. This is a utility fault; it will clear itself when the frequency comes within the specified range. †
Over Temp Fault 86.4C 178.5F	The unit’s internal temperature is greater than 85° C, the unit will shut down automatically and only restart when the temperature has dropped to less than 75° C.
Unit Shutdown via Remote	The GT Inverter unit has been shut down via a computer connected to the RS-232 port.
Protection uP Not Responding	The protection processor is not responding.

* It is normal to receive this fault during low light conditions at dawn or dusk. At such times, the PV voltage drops below the lower limit of the maximum power point range, and the array does not have sufficient energy to power the inverter.

† Grid fault. When this fault is cleared the protection timer will begin its countdown and you will see the *Reconnecting in sss seconds* and *Inverter Offline* special screens (see Table 5-10) flashing alternately until the countdown is complete.

Additional Fault messages for all systems

Additional message screens can be viewed in fault mode by tapping the front panel. Each additional tap displays the next screen in the order shown in Table 5-9.

Table 5-9 Additional Fault Mode Screens

Tap	Display*	Description
1st	Current fault message screen (see Table 5-8)	LCD backlight turns on for better readability.
2nd	System 0W Today 2.500kWh	Energy being produced by the system now. Cumulative energy produced by the system today.
3rd	System Lifetime 305kWh	Lifetime energy produced by the GT Inverter system.
4th	Time Online Today hh:mm:ss	Length of time inverter was online today, in hours (hh), minutes (mm) and seconds (ss).
5th	Array Readings 350.5V 8.4A	Immediate DC voltage and current readings of power from the PV array.
6th	Grid Readings 230.6V 50.0Hz	Immediate AC voltage and frequency readings of power from the Grid.

* In a multiple unit system with network cables installed, the system values displayed are for the entire system. Time online and array readings are for the local inverter and PV array associated with that inverter.

Special Screens

Special message screens are displayed in specific situations that are not considered fault situations. They can appear in any mode of operation. These screens are described in Table 5-10.

Table 5-10 Special Message Screens

Display	Description
Reconnecting in sss seconds	Time remaining in seconds (sss) before the GT Inverter reconnects to the Grid. This is a protection timer that runs at startup and after any Grid fault.
Inverter Offline	GT Inverter switching (or has switched) from Normal Operation to Offline mode. This screen may flash alternately with a Fault message screen.
System *3500W Today 15.56kWh	The asterisk (*) in these two screens (see Table 5-2 and Table 5-4) indicates that the unit is derating its output power because the inverter heat sink temperature is above 75 °C or 79 °C depending on model. The asterisk only appears when the power is actually being limited by the inverter.
Unit *1800W Today 7.82kWh	
Insufficient Solar Energy	Indicates the GT Inverter is not producing power due to insufficient solar energy during low light conditions in early morning or late afternoon or when the PV array is in shade. This screen flashes alternately with the Normal Operation default screen.

Custom Screens

Two custom screens are available. The inverter does not display them unless they are configured using GT-View (see page 3–16). If configured, the custom screens display as the fourth and fifth screens during the startup sequence. They can also be viewed by tapping the unit during normal operation and fault mode.

The first custom screen is intended for the home owner to display information such as the name or location of the PV array associated with the inverter.

The second custom screen is intended for installers, who can configure the screen to display, for example, contact information for service.

Status Indicator Lights

The GT Inverter is equipped with two status indicator lights (LEDs) located below the front panel LCD (Figure 5-2). These LEDs indicate the inverter's current status (Table 5-11) and assist in troubleshooting the performance of the unit.

Only one indicator light will be lit at any time.

Table 5-11 Status Indicator LEDs

LED on	Means
Green	GT Inverter is on (DC voltage and AC voltage are qualified and the protection timer has finished) and delivering energy to the grid. No action required. Turns off when a fault state is detected.
Red	Ground fault condition detected. Check for any fault messages on the display (see Table 5-8), and refer also to Table 6-1, "Troubleshooting the GT Inverter" on page 6-4 to resolve the fault condition.

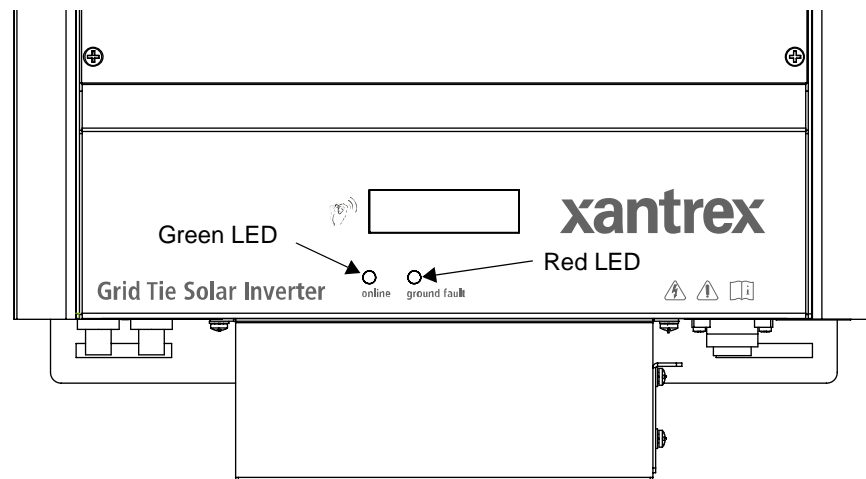

Figure 5-2 Location of Status Indicator Lights

6

Maintenance and Troubleshooting

5



WARNING: Electrical shock and fire hazard

Do not disassemble the GT Inverter. It does not contain any user serviceable parts. Attempting to service the unit yourself could result in electrical shock or fire.

Chapter 6, “Maintenance and Troubleshooting”, contains information about how to provide general maintenance for the Xantrex Grid Tie Solar Inverter. It also provides information about troubleshooting the unit.

The topics in this chapter are organized as follows:

- “Factors Affecting GT Inverter Performance” on page 6–2
- “Performing General Maintenance” on page 6–3
- “Identifying Error/Fault Conditions and Solutions” on page 6–3.

Factors Affecting GT Inverter Performance

This section describes several factors that will affect the amount of power that a properly installed and operating GT Inverter can produce.

PV Array Factors

PV array ratings	PV arrays are rated under standardized conditions, such as specified illumination (1000 W/m ²), spectrum of the light (Air Mass 1.5 standard reference spectrum), and specified temperature (25 °C), that seldom reflect real-world installations. This is called the STC (Standard Test Condition) rating and is the figure that appears on the PV module nameplate label.
Expected performance	A properly designed and installed PV system will produce less than its peak STC-rated output. Actual production depends on several unavoidable environmental factors described in this section.
Temperature and reduced output	PV array temperature affects the output of the entire system. As the temperature on the array surface heats up, its energy output goes down. Roof-mounted arrays also collect the heat generated by the roof surface (or trapped under the array) and will produce less output than pole-mounted arrays, which allow greater air circulation behind the panels.

Important: The GT Inverter will reduce its energy output to protect its electronic circuits from overheating and possible damage in high heat conditions. For maximum output in hot climates, mount the GT Inverter in a shaded location with good air flow.

Angle of the sun	The angle of the sun in relation to the PV array surface—the array orientation—can dramatically affect the PV array output. The array energy output will vary depending on the time of day and time of year as the sun’s angle in relation to the array changes. Incident sunlight decreases when the sun is near the horizons due to the greater atmospheric air that it must penetrate. This reduces both the light intensity that strikes the array’s surface and spectrum of the light. In general, you can expect only four to six hours of direct sunlight per day.
Partial shade	Shading of only a single module of the array will reduce the output of the entire system. Such shading can be caused by something as simple as the shadow of a utility wire or tree branch on part of the array’s surface. This condition, in effect, acts like a weak battery in a flashlight, reducing the total output, even though the other batteries are good. However, the output loss is not proportionate to shading. The GT Inverter is designed to maximize its energy production in all of the above situations using its MPPT algorithm.

Other Factors

Other factors that contribute to system losses are:

- Dust or dirt on the array
- Fog or smog
- Mismatched PV array modules, with slight inconsistencies in performance from one module to another.
- Inverter efficiency
- Wire losses

For additional information and technical notes concerning PV array performance, please visit our Web site at www.xantrex.com.

Performing General Maintenance

Follow these simple routines to ensure many years of service and optimal performance of your solar energy system.

1. Keep the heat sink clear of dust and debris.



WARNING: Shock and fire hazard

Do not use a pressure washer to clean the GT Inverter, or use other cleaning methods that could allow water to enter the unit.

2. Clean the PV array with flowing water whenever it is visibly dirty, during a cool time of the day.
3. Periodically inspect the system to make sure that all wiring and supports are securely in place.
4. Maintain a log of system performance readings so that you can recognize when system performance becomes inconsistent.

Identifying Error/Fault Conditions and Solutions



WARNING: Shock Hazard

This section is for qualified electricians only. Only qualified electricians should attempt to troubleshoot the GT Inverter.

Most error or fault conditions will be identified by fault message screens on the GT Inverter front panel LCD. These are described in the “Fault Mode” section on page 5–8. Most of these fault conditions are self-correcting and require no user action to remedy.

See “Front Panel Display Screens and What They Mean” on page 5–3 for more information.

Table 6-1 is intended to assist in determining fault conditions that may require user action to remedy.

Table 6-1 Troubleshooting the GT Inverter

Problem	Possible Cause	Solution
The inverter's LEDs and display are blank and the inverter does not operate in sufficient sunlight.	Utility service panel AC and DC breakers are switched off.	Turn on the breakers in the sequence described in "Commissioning Procedure" on page 4-2.
The display reads <i>Inverter Offline</i> and <i>AC Voltage Fault</i> .	Utility service panel breakers are switched off. AC grid voltage is not present or incorrect.	Turn on utility panel breakers. Check AC connections at the inverter's terminals. Ensure AC voltage within the range specified in "Output" on page A-2 is present.
The display reads <i>Inverter Offline</i> with sufficient sunlight.	DC breakers are switched off (if installed), or DC fuses are blown (if installed). DC array voltage is not present.	Turn on any DC breakers and check any DC fuses. Check DC connections at the inverter's positive and negative DC terminals. Check for incorrectly wired PV arrays.
The display reads <i>Inverter Offline</i> and <i>DC Voltage Fault</i> with sufficient sunlight.	DC voltage is present but incorrect.	Check DC connections at the inverter's positive and negative DC terminals. Check for incorrectly wired PV arrays. Ensure a voltage within the operating voltage range is present at the inverter's terminals.
Only the inverter RED LED is illuminated and the display reads <i>Ground Fault</i> .	Ground fault condition detected on the PV array.	The PV system should be checked by a qualified electrician and repaired. See "PV Ground Fault Detection" on page viii. To reconnect: <ol style="list-style-type: none"> 1. Make sure the GT Inverter is not outputting power, and then switch off the DC breaker. If a DC breaker is not used, then disconnect the DC input. 2. Switch off the AC breaker. 3. Remedy the actual ground fault. 4. Restart the unit using the sequence described in "Commissioning Procedure" on page 4-2.

Table 6-1 Troubleshooting the GT Inverter

Problem	Possible Cause	Solution
The <i>System</i> value (power being produced by the system) displayed on each inverter's LCD is different on inverters connected to the same daisy-chained network.	Inverters can display different <i>System</i> values when one of the inverters is set to a different baud rate than the rest. That particular inverter's baud rate screen shows Tx and/or Rx error (see Table 5-3 on page 5–6).	Check each inverter's baud rate and compare the settings. Change any inverters with an incorrect baud rate. Make sure to follow the recommended procedure supplied by Xantrex. See the Application Note, <i>Xantrex Grid Tie Solar Inverter Baud Rate Change Procedure</i> (976-0216-01-01 available on www.xantrex.com).

A

Specifications

Appendix A, “Specifications”, contains information about the electrical and environmental specifications of the Xantrex Grid Tie Solar Inverter.

The topics in this appendix are organized as follows:

- “Electrical Specifications” on page A-2
- “Environmental Specifications” on page A-5
- “Mechanical Specifications” on page A-5

All specifications are subject to change without notice.

Electrical Specifications

Input

	GT2.8-AU	GT5.0-AU
Input voltage, Maximum Power Point range	195 to 550 Vdc	240–550 Vdc
Absolute maximum array open circuit voltage	600 Vdc	
Maximum input current	15.4 Adc	22 Adc
Maximum array short circuit current	24 Adc	
Ground fault protection	Unit shut down if a high impedance is not detected. See “PV Ground Fault Detection” on page viii.	
Recommended PV array power*	3070 W	5300 W

*These values can change depending on environmental conditions. To ensure maximum power yield for your installation, the PV array size should be reviewed as part of the system design.

Output

	GT2.8-AU	GT5.0-AU
Maximum output power	2800 W ac	5000 W ac
Maximum output current	14.0 A	24.0 A
Nominal grid voltage	230 Vac	
Nominal grid frequency	50 Hz	
Total Harmonic Distortion (THD)	<3%	
Power factor	>0.99% (at rated power) >0.95% (full power range)	
Output characteristics	Current source	
Output current waveform	Sine wave	

Islanding Protection

Requirement	AS4777.3 Clause B4
Type	Active rate-of-change of voltage

Adjustable Disconnect Settings

Voltage and frequency disconnect and islanding protection are essential safety features that ensure no person working on the grid is harmed by a distributed energy source. Default software settings are programmed into each GT Inverter at the factory to ensure it does not island according to relevant safety regulations (AS4777.3 Clause B4) and that out-of-bounds voltage or frequency results in disconnection as required (AS4777.3 Clause B2 and B3).

In some instances it may be desirable to adjust these default settings. For example, the GT Inverter may experience nuisance trips (taking the inverter offline) if the grid is weak and the voltage falls outside the allowable range specified in the regulations. With permission from the utility, the factory settings may be changed to allow the GT inverter to operate over a wider grid voltage range.

The utility disconnect settings are password protected and should only be changed by qualified service personnel, using the Xantrex GTConfigLite software tool. For more information about installing and using GTConfigLite, see the *GTConfigLite User's Guide*, available with the software.

Default Utility Disconnect Settings and Adjustment Ranges

Setting	Default	Min	Max
Phase-to-Phase (rms) High Threshold Voltage	265.00	230.00	270.00
Phase-to-Phase (rms) Reconnect Voltage	265.00	230.00	270.00
Phase-to-Phase (rms) Low Threshold Voltage	203.00	200.00	230.00
Voltage (rms) High Clearing Time (ms)	2000	2000	5000
Voltage (rms) Low Clearing Time (ms)	2000	2000	5000
Frequency High Threshold (Hz)	51.00	50.00	55.00
Frequency Low Threshold (Hz)	48.00	45.00	50.00
Frequency High Clearing Time (ms)	2000	2000	10100
Frequency Low Clearing Time (ms)	2000	2000	10100
Reconnect Delay (ms)	60000	10000	305000

Output Power Versus Ambient Temperature

Once the heat sink on the inverter reaches a temperature limit, the GT Inverter reduces its energy output to ensure maximum component ratings are not exceeded. The following shows the maximum continuous output power derating to be expected at higher ambient temperatures.

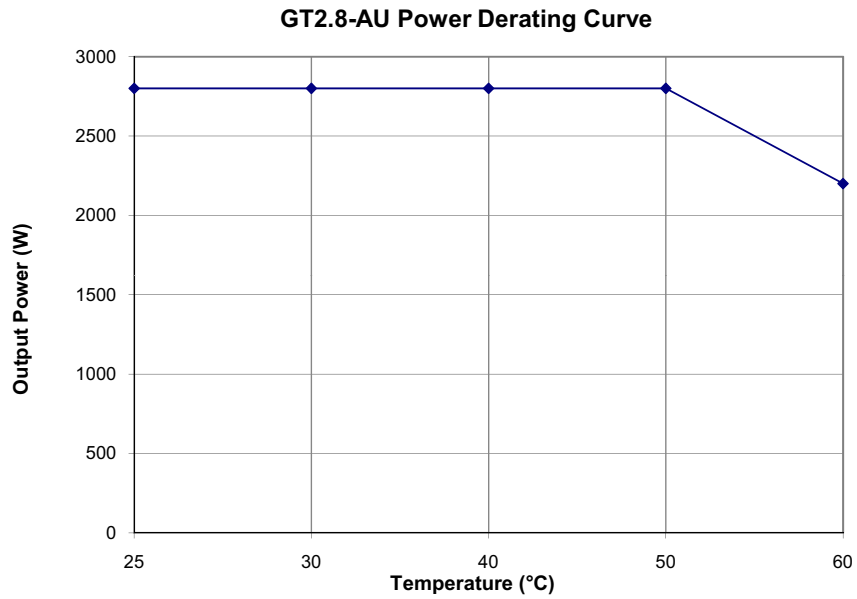

Figure A-1 Output Power vs. Ambient Temperature (GT2.8-AU)

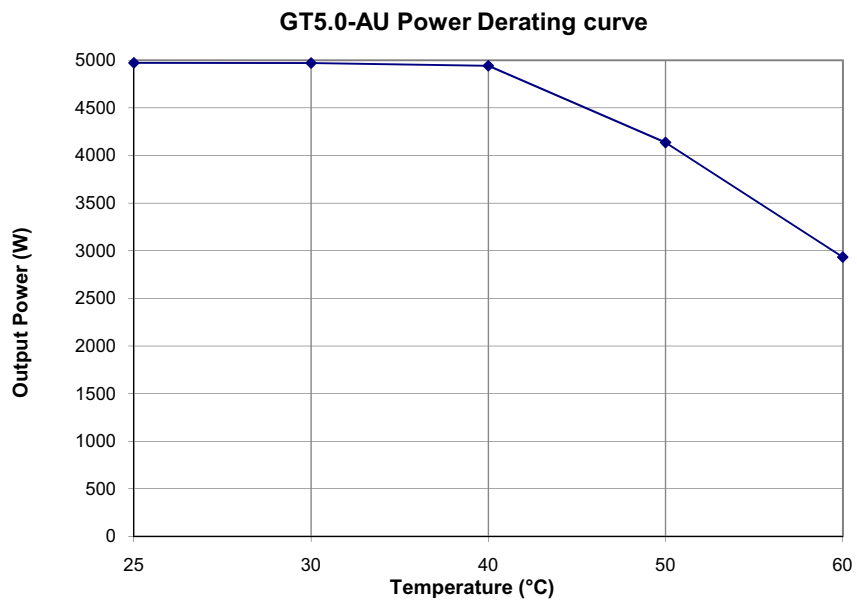

Figure A-2 Output Power vs. Ambient Temperature (GT5.0-AU)

Efficiency

	GT 2.8-AU	GT 5.0-AU
Maximum peak efficiency	95%	96%
Nighttime tare loss	1 W	

Environmental Specifications

Operating temperature range	-25 to +65 °C
Storage temperature range	-40 to +85 °C
Power derating	See Figure A-1 and Figure A-2.
Tolerable relative humidity limit	Operating: <95%, non-condensing Storage: 100% condensing
Outdoor enclosure	IP54, Rainproof

User Display

Type	alphanumeric liquid crystal with backlight
Size	2 lines by 16 characters

Display Accuracy

Instantaneous Power	+/- (30 W + 1% of reading)
Voltage	+/- (1% of rating + 1% of reading)
Current	+/- (1% of rating + 1% of reading)
System Lifetime energy	+/- 5%

Mechanical Specifications

	GT2.8-AU	GT5.0-AU
Inverter dimensions (H × W × D)	597 × 403 × 136 mm	
Shipping dimensions (H × W × D)	692 × 518 × 262 mm	
Inverter weight	19.5 kg	22.3 kg
Shipping weight	25.5 kg	27.2
Input terminals	Multi-contact Quick Connect PV-ADSP3/GWD (male) PV-ADBP3/GWD (female)	
Output terminals (2.8-AU only)	Binder 693 Series male socket (mates with supplied female cable connector PG13,5 p/n 99-4222-14-04)	

Warranty and Return Information

Warranty

What does this warranty cover and how long does it last? This Limited Warranty is provided by Xantrex Technology Inc. ("Xantrex") and covers defects in workmanship and materials in your Xantrex Grid Tie Solar Inverter. This Warranty Period lasts for five years from the date of purchase at the point of sale to you, the original end user customer, unless otherwise agreed in writing. You will be required to demonstrate proof of purchase to make warranty claims.

This Limited Warranty is transferable to subsequent owners but only for the unexpired portion of the Warranty Period. Subsequent owners also require original proof of purchase as described in "What proof of purchase is required?"

What will Xantrex do? During the Warranty Period Xantrex will, at its option, repair the product (if economically feasible) or replace the defective product free of charge, provided that you notify Xantrex of the product defect within the Warranty Period, and provided that Xantrex through inspection establishes the existence of such a defect and that it is covered by this Limited Warranty.

Xantrex will, at its option, use new and/or reconditioned parts in performing warranty repair and building replacement products. Xantrex reserves the right to use parts or products of original or improved design in the repair or replacement. If Xantrex repairs or replaces a product, its warranty continues for the remaining portion of the original Warranty Period or 90 days from the date of the return shipment to the customer, whichever is greater. All replaced products and all parts removed from repaired products become the property of Xantrex.

Xantrex covers both parts and labor necessary to repair the product, and return shipment to the customer via a Xantrex-selected non-expedited surface freight within the contiguous United States and Canada. Alaska, Hawaii and outside of the United States and Canada are excluded. Contact Xantrex Customer Service for details on freight policy for return shipments from excluded areas.

How do you get service? If your product requires troubleshooting or warranty service, contact your merchant. If you are unable to contact your merchant, or the merchant is unable to provide service, contact Xantrex directly at:

Telephone: 1 408 987 6030
Fax: 1 604 422 2756
Email: customerservice@xantrex.com
Website: www.xantrex.com

Direct returns may be performed according to the Xantrex Return Material Authorization Policy described in your product manual. For some products, Xantrex maintains a network of regional Authorized Service Centers. Call Xantrex or check our website to see if your product can be repaired at one of these facilities.

What proof of purchase is required? In any warranty claim, dated proof of purchase must accompany the product and the product must not have been disassembled or modified without prior written authorization by Xantrex.

Proof of purchase may be in any one of the following forms:

- The dated purchase receipt from the original purchase of the product at point of sale to the end user; or
- The dated dealer invoice or purchase receipt showing original equipment manufacturer (OEM) status; or
- The dated invoice or purchase receipt showing the product exchanged under warranty.

What does this warranty not cover? Claims are limited to repair and replacement, or if in Xantrex's discretion that is not possible, reimbursement up to the purchase price paid for the product. Xantrex will be liable to you only for direct damages suffered by you and only up to a maximum amount equal to the purchase price of the product.

This Limited Warranty does not warrant uninterrupted or error-free operation of the product or cover normal wear and tear of the product or costs related to the removal, installation, or troubleshooting of the customer's electrical systems. This warranty does not apply to and Xantrex will not be responsible for any defect in or damage to:

- a) the product if it has been misused, neglected, improperly installed, physically damaged or altered, either internally or externally, or damaged from improper use or use in an unsuitable environment;
- b) the product if it has been subjected to fire, water, generalized corrosion, biological infestations, or input voltage that creates operating conditions beyond the maximum or minimum limits listed in the Xantrex product specifications including, but not limited to, high input voltage from generators and lightning strikes;
- c) the product if repairs have been done to it other than by Xantrex or its authorized service centers (hereafter "ASCs");
- d) the product if it is used as a component part of a product expressly warranted by another manufacturer;
- e) component parts or monitoring systems supplied by you or purchased by Xantrex at your direction for incorporation into the product;
- f) the product if its original identification (trade-mark, serial number) markings have been defaced, altered, or removed;
- g) the product if it is located outside of the country where it was purchased; and
- h) any consequential losses that are attributable to the product losing power whether by product malfunction, installation error or misuse.

Disclaimer

Product

THIS LIMITED WARRANTY IS THE SOLE AND EXCLUSIVE WARRANTY PROVIDED BY XANTREX IN CONNECTION WITH YOUR XANTREX PRODUCT AND IS, WHERE PERMITTED BY LAW, IN LIEU OF ALL OTHER WARRANTIES, CONDITIONS, GUARANTEES, REPRESENTATIONS, OBLIGATIONS AND LIABILITIES, EXPRESS OR IMPLIED, STATUTORY OR OTHERWISE IN CONNECTION WITH THE PRODUCT, HOWEVER ARISING (WHETHER BY CONTRACT, TORT, NEGLIGENCE, PRINCIPLES OF MANUFACTURER'S LIABILITY, OPERATION OF LAW, CONDUCT, STATEMENT OR OTHERWISE), INCLUDING WITHOUT RESTRICTION ANY IMPLIED WARRANTY OR CONDITION OF QUALITY, MERCHANTABILITY OR FITNESS FOR A PARTICULAR PURPOSE. ANY IMPLIED WARRANTY OF MERCHANTABILITY OR FITNESS FOR A PARTICULAR PURPOSE TO THE EXTENT REQUIRED UNDER APPLICABLE LAW TO APPLY TO THE PRODUCT SHALL BE LIMITED IN DURATION TO THE PERIOD STIPULATED UNDER THIS LIMITED WARRANTY.

IN NO EVENT WILL XANTREX BE LIABLE FOR: (A) ANY SPECIAL, INDIRECT, INCIDENTAL OR CONSEQUENTIAL DAMAGES, INCLUDING LOST PROFITS, LOST REVENUES, FAILURE TO REALIZE EXPECTED SAVINGS, OR OTHER COMMERCIAL OR ECONOMIC LOSSES OF ANY KIND, EVEN IF XANTREX HAS BEEN ADVISED, OR HAD REASON TO KNOW, OF THE POSSIBILITY OF SUCH DAMAGE, (B) ANY LIABILITY ARISING IN TORT, WHETHER OR NOT ARISING OUT OF XANTREX'S NEGLIGENCE, AND ALL LOSSES OR DAMAGES TO ANY PROPERTY OR FOR ANY PERSONAL INJURY OR ECONOMIC LOSS OR DAMAGE CAUSED BY THE CONNECTION OF A PRODUCT TO ANY OTHER DEVICE OR SYSTEM, AND (C) ANY DAMAGE OR INJURY ARISING FROM OR AS A RESULT OF MISUSE OR ABUSE, OR THE INCORRECT INSTALLATION, INTEGRATION OR OPERATION OF THE PRODUCT.

IF YOU ARE A CONSUMER (RATHER THAN A PURCHASER OF THE PRODUCT IN THE COURSE OF A BUSINESS) AND PURCHASED THE PRODUCT IN A MEMBER STATE OF THE EUROPEAN UNION, THIS LIMITED WARRANTY SHALL BE SUBJECT TO YOUR STATUTORY RIGHTS AS A CONSUMER UNDER THE EUROPEAN UNION PRODUCT WARRANTY DIRECTIVE 1999/44/EC AND AS SUCH DIRECTIVE HAS BEEN IMPLEMENTED IN THE EUROPEAN UNION MEMBER STATE WHERE YOU PURCHASED THE PRODUCT. FURTHER, WHILE THIS LIMITED WARRANTY GIVES YOU SPECIFIC LEGAL RIGHTS, YOU MAY HAVE OTHER RIGHTS WHICH MAY VARY FROM EU MEMBER STATE TO EU MEMBER STATE OR, IF YOU DID NOT PURCHASE THE PRODUCT IN AN EU MEMBER STATE, IN THE COUNTRY YOU PURCHASED THE PRODUCT WHICH MAY VARY FROM COUNTRY TO COUNTRY AND JURISDICTION TO JURISDICTION.

Return Material Authorization Policy

For those products that are not being repaired in the field and are being returned to Xantrex, before returning a product directly to Xantrex you must obtain a Return Material Authorization (RMA) number and the correct factory "Ship To" address. Products must also be shipped prepaid. Product shipments will be refused and returned at your expense if they are unauthorized, returned without an RMA number clearly marked on the outside of the shipping box, if they are shipped collect, or if they are shipped to the wrong location.

When you contact Xantrex to obtain service, please have your instruction manual ready for reference and be prepared to supply:

- The serial number of your product
- Information about the installation and use of the unit
- Information about the failure and/or reason for the return
- A copy of your dated proof of purchase

Record these details on page WA-4.

Return Procedure

Package the unit safely, preferably using the original box and packing materials. Please ensure that your product is shipped fully insured in the original packaging or equivalent. This warranty will not apply where the product is damaged due to improper packaging.

Include the following:

- The RMA number supplied by Xantrex Technology Inc. clearly marked on the outside of the box.
- A return address where the unit can be shipped. Post office boxes are not acceptable.
- A contact telephone number where you can be reached during work hours.
- A brief description of the problem.

Ship the unit prepaid to the address provided by your Xantrex customer service representative.

If you are returning a product from outside of the USA or Canada In addition to the above, you **MUST** include return freight funds and are fully responsible for all documents, duties, tariffs, and deposits.

If you are returning a product to a Xantrex Authorized Service Center (ASC) A Xantrex return material authorization (RMA) number is not required. However, you must contact the ASC prior to returning the product or presenting the unit to verify any return procedures that may apply to that particular facility and that the ASC repairs this particular Xantrex product.

Out of Warranty Service

If the warranty period for your product has expired, if the unit was damaged by misuse or incorrect installation, if other conditions of the warranty have not been met, or if no dated proof of purchase is available, your unit may be serviced or replaced for a flat fee.

To return your product for out of warranty service, contact Xantrex Customer Service for a Return Material Authorization (RMA) number and follow the other steps outlined in "Return Procedure" on page WA-3.

Payment options such as credit card or money order will be explained by the Customer Service Representative. In cases where the minimum flat fee does not apply, as with incomplete units or units with excessive damage, an additional fee will be charged. If applicable, you will be contacted by Customer Service once your unit has been received.

Information About Your System

As soon as you open your Xantrex Grid Tie Solar Inverter package, record the following information and be sure to keep your proof of purchase.

- Serial Number _____
- Product Number 864-1030 (GT2.8-AU-QC-230) and
864-1039 (GT5.0-AU-QC-230)
- Purchased From _____
- Purchase Date _____

If you need to contact Customer Service, please record the following details before calling. This information will help our representatives give you better service.

- Type of installation _____
- Length of time inverter has been installed _____
- DC wiring size and length _____
- Description of indicators on front panel _____
- Description of problem _____

Index

A

abbreviations and symbols iv
AC circuit breaker requirements 2–9
AC grounding requirements 2–7
AC output voltage ratings A–2
AC wiring instructions 3–7
adjustable disconnect settings A–3

C

communication between multiple inverters 3–10
communications cabling 3–13
 installing for multiple inverters 3–14
Customer Service
 preparing to call WA–4

D

DC fuse requirements 3–3
DC wiring instructions 3–4
derating chart A–4
dimensions 2–11, A–5
display accuracy A–5

E

efficiency chart A–5
electrical specifications A–2
error messages and solutions 6–4

F

fault conditions and solutions 6–4
features and options 1–3
front panel display 1–3, 5–2
 fault messages 5–8
 normal operation messages 5–5
 offline mode messages 5–7
 reading messages 5–3
 special messages 5–10
 startup messages 5–3
fuses 3–3

G

general maintenance 6–3
ground clearance required for installation 2–4, 2–12
ground fault detection viii

grounding requirements 2–7
GT-View 3–16

H

humidity limits A–5

I

Information about Your System form WA–4
installation
 grounding requirements 2–7
 location concerns 2–4
 mounting 2–13
 options 2–2
 overview 2–9
 planning issues 2–2
 preparing for 2–8
 PV array requirements 2–5
 routing wires 2–8
inverter
 features and options 1–3
 installation 2–9
 purchase date WA–4
 purpose 1–2
 serial number WA–4

L

LEDs, *See* status LEDs
lightning protection 2–8

M

maintenance, general 6–3
maximum power point tracking, *See* MPPT
mechanical specifications A–5
messages, *See* front panel display
mounting bracket
 installing 2–12
 on backing support 2–15
 on poles or rails 2–14
mounting the inverter
 clearance requirements 2–12
 on wallboard, siding or concrete 2–15
 orientation 2–4
 overview 2–10
 preparation 2–11

- single inverter 2–16
- surfaces for 2–13
- using poles or rails 2–14

MPPT

- operational window 2–5
- technology 1–3

multiple inverters

- communication between 3–10
- communications wiring 3–14
- configuration 2–2
- installation 3–6
- messages in normal operation 5–6
- messages in offline mode 5–8

O

operation

- factors affecting performance 6–2
- messages at startup 5–3
- startup procedure 4–2

P

- photovoltaic (PV) power 1–2
- power derating A–5
- preparing for installation 2–8
- proof of purchase WA–4
- purchase date WA–4

PV arrays

- angle of the sun 6–2
- effect of shade on performance 6–2
- factory ratings 6–2
- installation recommendations 2–5
- matching size to inverter input 2–6
- requirements 2–5
- temperature affecting performance 6–2
- types of modules 2–5
- voltage requirements 2–6

R

RJ45 ports

- communication between inverters 3–12

RS-232 port 3–12, 3–16, 5–9

S

- safety instructions vii
- serial number WA–4
- single inverter configuration 2–2

specifications

- electrical A–2
- mechanical A–5

- standard features and options 1–3
- standard test condition 6–2
- startup procedure
 - monitor front panel display 5–2
 - overview 4–2
- status LEDs
 - description 5–11
 - do not illuminate 6–4
 - red LED is on 6–4

T

temperature

- affecting PV array performance 6–2
- range for locating Xantrex GT Inverter 2–4

thermal derating chart A–4

troubleshooting the GT Inverter 6–4

U

- utility disconnect settings 5–4

W

warranty

- terms and conditions WA–1

weight A–5

wire stripping length, recommended 2–8

wiring

- information 2–8
- preparation for 2–8
- PV array to Xantrex GT Inverter 3–4
- routing wires 2–8

X

- Xanbus technology 3–10
- Xantrex web site v

Xantrex Technology Inc.

1 408 987 6030 (Telephone)
1 604 422 2756 (Fax)
customerservice@xantrex.com
www.xantrex.com