

# INSTALLATION MANUAL

## Roof Mount Solar Hot Water System



# CONTENTS

1 .....	Important Information
2 .....	Installation
3 .....	Electrical Connections
4 .....	Maintenance
5 .....	Troubleshooting

# HOT WATER CAN CAUSE SERIOUS INJURY



**WARNING - Hot Water is dangerous!** As a safety precaution, young children should always be supervised around hot water fixtures

WARNING — THIS APPLIANCE MAY DELIVER WATER AT HIGH TEMPERATURE. REFER TO THE PLUMBING CODE OF AUSTRALIA (PCA), LOCAL REQUIREMENTS AND INSTALLATION INSTRUCTIONS TO DETERMINE IF ADDITIONAL DELIVERY TEMPERATURE CONTROL IS REQUIRED.

THIS WATER HEATER IS ONLY INTENDED TO BE OPERATED BY PERSONS WHO HAVE THE EXPERIENCE OR THE KNOWLEDGE AND THE CAPABILITIES TO DO SO. THIS WATER HEATER IS NOT INTENDED TO BE OPERATED BY PERSONS WITH REDUCED PHYSICAL, SENSORY OR MENTAL CAPABILITIES IE: THE INFIRM AND CHILDREN.

As solar water heaters can generate water temperature in excess of 80°C, regulations require that an approved solar rated tempering valve shall be installed in accordance with the valve manufacturer's instructions. This is required to prevent water temperatures supplied to the house exceeding a preset safe maximum. The tempering valve is connected to the hot water outlet lines. The valve must be fitted by an authorised plumber at the time of installation or in retrofitting to existing systems.

CHECK THE WATER TEMPERATURE BEFORE USE, SUCH AS WHEN ENTERING A SHOWER OR FILLING A BATH OR BASIN, TO ENSURE IT SUITABLE FOR THE APPLICATION AND WILL NOT CAUSE SCALD INJURY.

Hot water systems can store water at temperatures that can cause scalding. Water temperatures over 50°C can scald and care needs to be taken to ensure that injuries do not occur through incorrect use of your water heater.

THIS WATER HEATER USES 240V AC POWER FOR THE ELECTRICALLY OPERATED COMPONENTS.

THE REMOVAL OR ATTEMPTED ALTERATION OF ANY ELECTRICAL COMPONENT MUST BE CONDUCTED BY A QUALIFIED ELECTRICAL SERVICE PERSON.

Care should be taken to avoid coming into contact with any pipe work or fixtures associated with the water heater collector flow and return lines.

FOR CONTINUED SAFETY OF THIS APPLIANCE, IT MUST BE INSTALLED, OPERATED AND MAINTAINED IN ACCORDANCE WITH THE MANUFACTURERS INSTRUCTIONS.

Water from the solar collectors can be hot enough to create pressurized steam which can cause severe scalding - under NO circumstances should any alterations be made by unauthorised personnel.

IN ORDER TO KILL LEGIONELLA BACTERIA IT IS AN AUSTRALIAN STANDARDS REQUIREMENT (AS3498) THAT THE HOT WATER IN THE STORAGE TANK BE HEATED UP TO AT LEAST 60°C ON A REGULAR BASIS, EITHER WHILE IN THE STORAGE TANK (SOLAR / ELECTRIC) OR BY A POST BOOST SET AT 70°C (GAS CONTINUOUS FLOW).

## Pressure Reduction Valve (PRV 500)

A pressure reduction valve of 500kPa maximum must be fitted immediately downstream of the cold water non-return isolation valve. **Failure to install a pressure reduction valve will void the warranty. Please note cold water supply line to the tempering valve must be run after the PRV to ensure equal supply pressure to the tempering valve. If the water supply pressure exceeds the rated pressure, a pressure reducing valve is to be fitted to the installation.**

**Note:** In SA, WA & QLD (and some other areas of other states subject to local authority regulations) it is a requirement that an expansion control valve be fitted between the non-return isolating valve and the water heater.

## Pressure Temperature Relief Valve (PTR)

An 850kPa, 10kW and 99°C PTR valve is used on the Solargain water tank, which is located on the side of the water tank and is essential for its safe operation. The PTR valve is designed to allow 3-5% of total tank volume to discharge during heating to allow for hot water expansion. Water may drip from the discharge pipe of the pressure-relief valve. The discharge pipe must be left open to the atmosphere under all circumstances. PTR Valve the discharge pipe shall be installed downwards and with discharge pipes in a frost free environment. Refer page 9 & 10 for how to connect. Seal the thread with approved sealant such as Teflon tape and screw the valve into the correct opening and leave the valve outlet pointing downwards.



**DANGER:** Failure to operate the relief valve easing gear at least once every six months may result in the water heater exploding. Continuous leakage of water from the valve may indicate a problem with the water heater.

## Standards and regulatory Requirements

All Solargain solar hot water systems must be installed by an authorized plumber. All installation work must meet local authority standards, Australian standard (AS 3500.4) and the Plumbing Code of Australia (PCA) along with local electrical regulations. Where required, the relevant electrical and plumbing work will need to be certified to the satisfaction of local regulatory authorities.

## Solar Hot Water Storage Tank

To obtain maximum performance the solar tank/system should be positioned as close as practical to the most used hot water outlets. This will reduce the amount of "lag time" which is the amount of cold water discharged through the outlet before the hot water reaches the outlet.

## Frost Protection

Solargain's 'Close Coupled' open loop systems are designed to be installed with a Frost Protection Valve in areas subject to freezing conditions. Solargain's close coupled systems have been tested to level 2 - severe frost condition according to AS/NZS 2712:2007 Appendix E with the use of an approved Frost Protection Valve. Warranty will not apply to frost damage collectors if the Frost Valve is determined to be faulty for any reason, including valve failure except within the first 12 months.

## Going away on holidays?

If the water heater is left unused for two weeks or more, a small quantity of hydrogen gas (which is HIGHLY flammable) may accumulate in the top water cylinder. To dissipate this gas safely it is recommended that a sink or bath hot tap be turned on to dispel a couple of litres of water. During this procedure there should be no smoking, open flames or any electrical appliances such as washing machines or dish washers operating nearby. If Hydrogen is discharged through the tap, it will make a sound like air escaping.

## Health & Safety

Solar hot water systems can be heavy so always use approved lifting devices when installing solar hot water systems at heights. All workplace health and safety regulation must be adhered to by the installer. Solargain Pty Ltd will not be held responsible for any damage to person or property that results during the installation or subsequent use of this solar collector and related components.

## Water Quality

Water in direct flow through Solargain Hot Water system must meet the following requirements.

Total hardness	200 mg/litre or p.p.m
Total dissolved solids	600 mg/litre or p.p.m
Electrical conductivity	850 $\mu$ S/cm
Chloride	250 mg/litre or p.p.m
Magnesium	10 mg/litre or p.p.m
Sodium	150 mg/litre or p.p.m
pH	6.5 to Max 8.5.

## Additional Roof Support Requirement

Refer to the Technical Specifications section for the weight of the water heater. It is advisable that the weight of the water heater be braced to a load bearing wall. The tank will need to span a minimum of 2 roof trusses no more than 900mm apart. If in any doubt of the construction or the condition of the roof, obtain advice from a registered builder or structural engineer. The installer must ensure that the structural integrity of the roof is not compromised by the installation of the solar water heater.

## Selecting System Location

Solargain collectors should be installed as close as possible to True North. If True North is not an option, the next most suitable direction is within 45 degrees either side of true north. If there is a necessity to install Solargain close coupled in a direction outside the 45 degrees mentioned above, Solargain Hot Water systems with derive sufficient solar contribution to comply with government requirements provided the following conditions are observed:

- The direction of the Solargain Closed Coupled system is no more than 90° either side of True North
- **The pitch of the roof or surface upon which the Solargain Close Coupled system is installed is no greater than 28°. Important: Hooping irons must be used for installs above 25° .**

The inclination of the Solargain Close Coupled system should ideally be the same as the latitude angle of the site.

Inclinations within 20° of the latitude angle of the site will only reduce efficiency by approximately 5%. Most roofs within Australia have a slope of between 20° and 25° and provide an appropriately angled mounting surface. To ensure operation of the system the inclination SHALL NOT be less than 10°. For maximum performance the Solargain Close Coupled system should be located in a position clear from shade all year round and free from obstructions.

City	Latitude	City	Latitude	City	Latitude	City	Latitude
Adelaide	35° S	Cairns	17° S	Hobart	42° S	Port Hedland	20° S
Alice Springs	24° S	Canberra	35° S	Mildura	34° S	Rock Hampton	24° S
Brisbane	27° S	Darwin	12° S	Melbourne	38° S	Sydney	34° S
Broken Hill	31° S	Geraldton	28° S	Perth	32° S	Townsville	19° S

# INSTALLATION

## Important

For correct thermosiphon operation, the collectors shall slope between 8-10mm from the inlet to the outlet. Please see adjacent diagram.

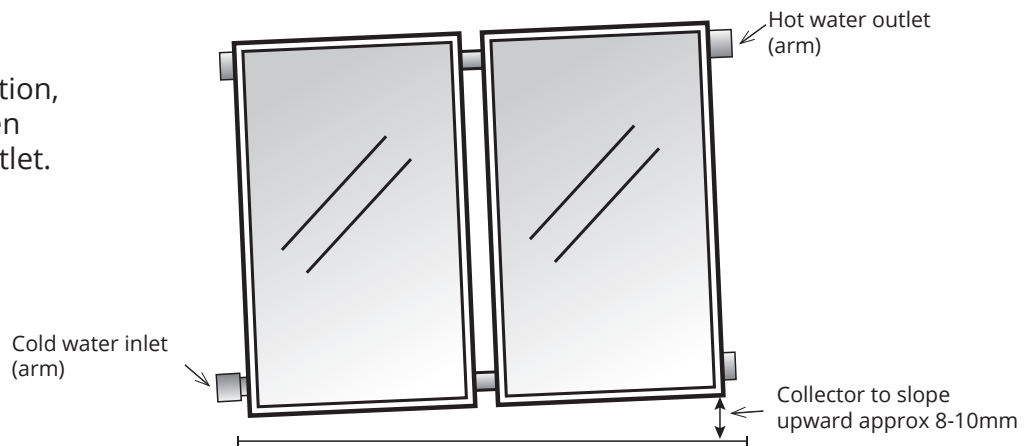

## Quick Installation Guide



*For tile roof installations, double check all tiles have been re-installed and sitting correctly. Failure to do so will result in possible water ingress to home.*

Using approved lifting method, place the collector/s into position on the bottom rail. Check the panel is in the correct position to allow the tank base to be located directly over the tile batten or metal roof batten. Using the 22mm panel unions, connect the panels together (if more than 1 panel) and tighten firmly.

**SPECIAL CARE MUST BE TAKEN WHEN TIGHTENING UNIONS TO COPPER TO ENSURE NO TWISTING OR DEFORMATION OF COLLECTOR COPPER HEADER PIPE OCCURS. 2 (TWO) SHIFTERS MUST BE USED AT ALL TIMES – ONE SHIFTER ON THE BODY OF THE FITTING AND ONE SHIFTER ON THE NUT.**

Ensure collector is centre of the bottom rail and once satisfied, attached the rail to collectors using the screws supplied.



*For tile roof installations, it is recommended that a suitable flashing is now installed underneath the location of the tank.*

Lift the storage tank into position and centralise its location on the top of the collector/s. Connect the tank straps supplied to the provision on the rear of tank. For metal roof installations, roof and gutter silicone shall be used between the strap and roof. Fix the rear tank straps the roof rafters/battens.

Using the connection fittings and pipes supplied, connect the tank and collector/s together. In areas of frost, a freeze protection valve shall be connected via a  $\frac{3}{4}$  x  $\frac{1}{2}$  brass hex nipple in place of the bottom collector plug.

## Step-by-step Installation Guide



Select rail location; insert straps through slots in rail & screw to batten. For tile roof, attach strap directly to truss and re-seat tile. Ensure panels have 8-10mm collector slope from inlet to outlet. This slope must be achieved to ensure correct level of thermosiphon.

*TIP: For tin roof installations, double check the screws are tightened firmly to avoid roof leaks.*



Place first panel onto rail and ensure bottom of panel is sitting flat on the rail. Ensure the 22mm panel unions are connected to the first panel. Using two shifters, one placed on the nut & one placed on the barrel of the union, tighten the nut of the 22mm union to the 22mm copper header pipe. **DO NOT TWIST COPPER HEADER PIPE AS THIS WILL CAUSE INTERNAL DAMAGE AND NOT COVERED BY WARRANTY.** Leave nut & olive on open end for connection of the second panel.



Place second panel & ensure both panels are square. Then gently slide both panels together and ensure 22mm copper header pipe is fully inserted into the 22mm panel union. Once both bottom and top 22mm panel unions are fully inserted, using 2 shifters, place one shifter on the nut & one shifter on the barrel of the union and tighten the 22 mm nut. **DO NOT TWIST COPPER HEADER PIPE AS THIS WILL CAUSE INTERNAL DAMAGE AND NOT COVERED BY WARRANTY.**



Align panels to centre of the aluminium bottom rail then screw the supplied 4 x Metal Self Tapping hex head screws into the 4 x pre-drilled holes in bottom rail.

*TIP: Now's a good time to clear the roof space of any obstacles for tank positioning.*



Place tank into position, resting the front leg of the base against the top of the panels. Ensure the centre of the base is centre of the panels. Tank connections are left hand only.

*TIP: Utilise the centre hole on the base to accurately position the tank dead centre.*



Utilising the 2 stainless steel straps bent at 90 degrees, insert bolt through the smaller round provisions then place stainless steel strap through bolt and tighten with provided nut. Repeat this step for both provisions on left and right hand side of the base. Then screw the strap to tin roof through existing batten screw. For tile roof, strap is be screwed into the truss and then tile re-seated.

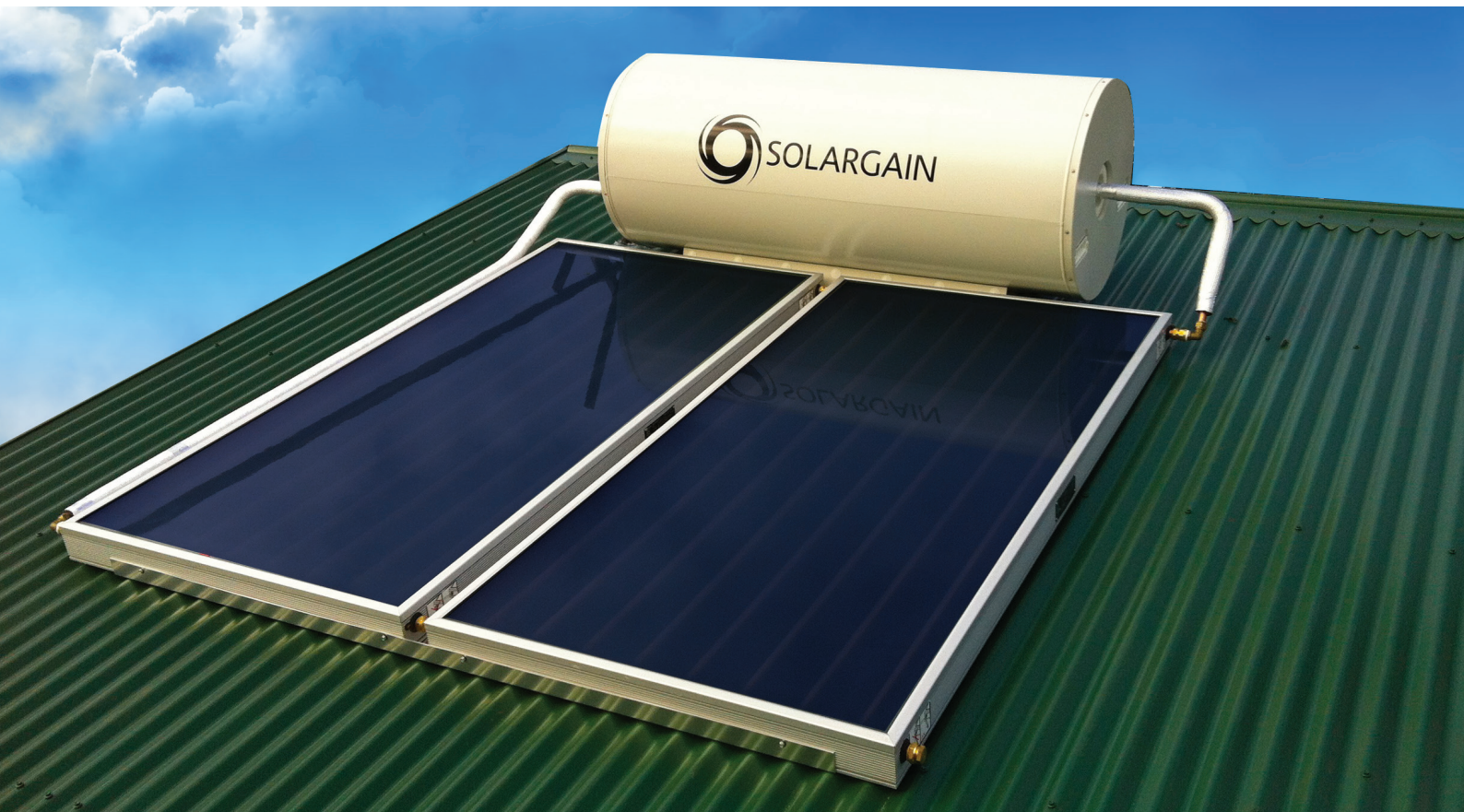



## Roof Mount Double Panel (Thermosiphon) Open Loop System

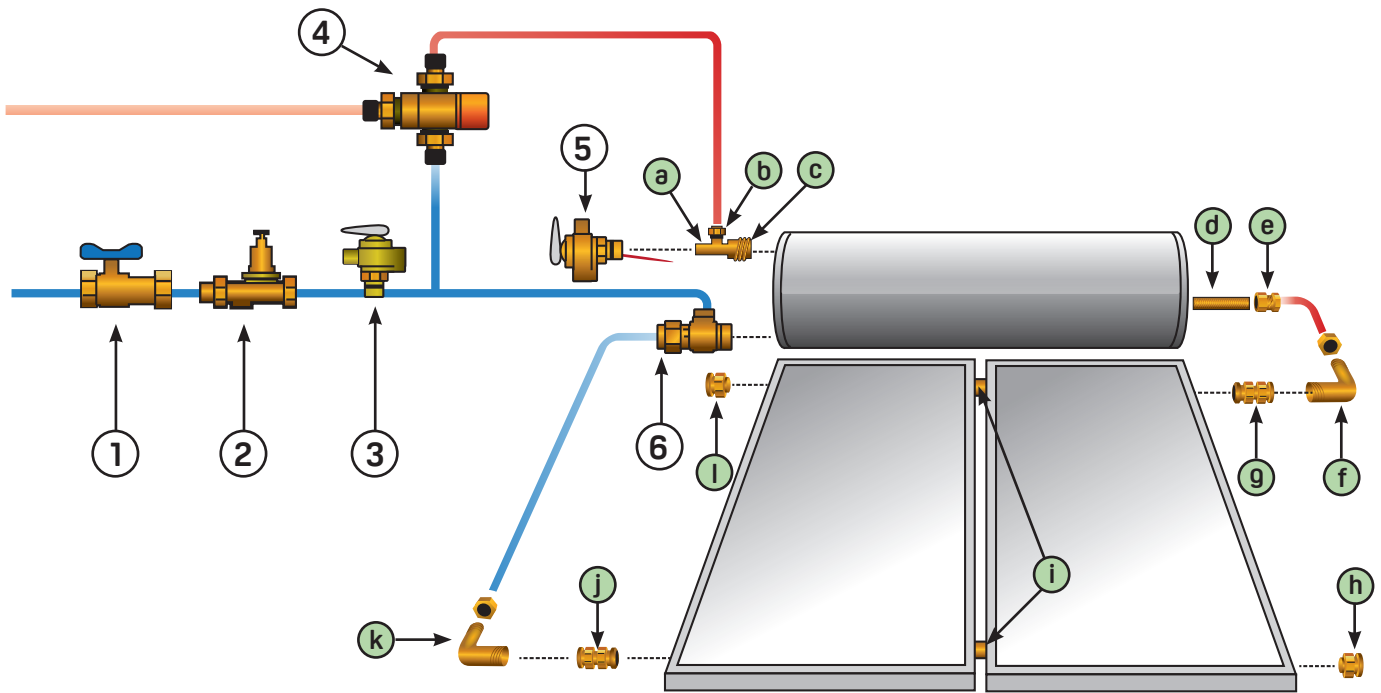

### Fittings

a	15 mm brass tee
b	15 mm MI x 15 mm conetite union
c	3/4 x 1/2 reducing hex nipple
d	3/4 brass thread
e	3/4 FI x 20 mm conetite union
f	3/4 MI x 20 mm conetite elbow
g	22 mm x 3/4 FI union
h	22 mm brass plug
i	22 mm panel union
j	22 mm x 3/4 FI union
k	3/4 MI x 20mm conetite elbow
l	22 mm brass plug

### Valve Assembly

1	Duo valve (supplied by installer)
2	500 kPa pressure reduction valve (supplied by installer)
3	700 kPa ECV (supplied by installer)
4	High performance tempering valve (supplied by installer)
5	850 kPa PTR valve (pressure temperature relief)
6	Thermosiphon arrestor valve

**TIP:** The UV Solar Rated pipe insulation provided shall be used for the hot and cold arm assemblies.

## Roof Mount Single Panel (Thermosiphon) Open Loop System

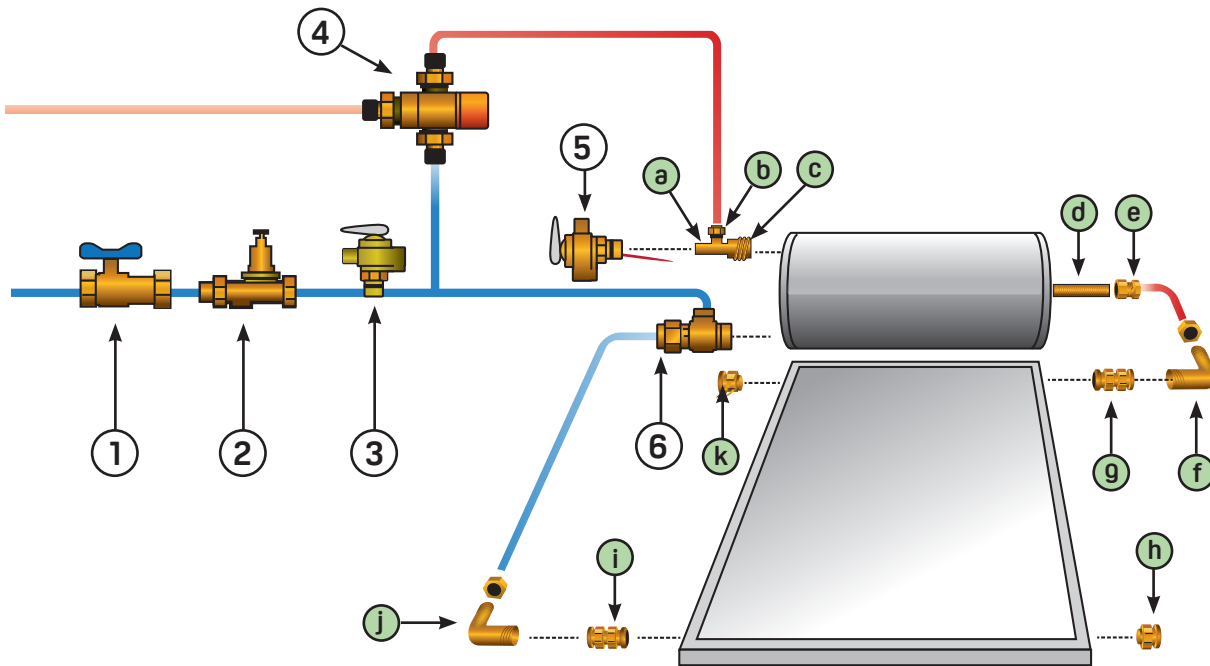

### Fittings

a	15 mm brass tee
b	15 mm MI x 15 mm conetite union
c	3/4 x 1/2 reducing hex nipple
d	3/4 brass thread
e	3/4 FI x 20 mm conetite union
f	3/4 MI x 20 mm conetite elbow
g	22 mm x 3/4 FI union
h	22 mm brass plug
i	22 mm panel union
j	22 mm x 3/4 FI union
k	3/4 MI x 20mm conetite elbow
l	22 mm brass plug

### Valve Assembly

1	Duo valve (supplied by installer)
2	500 kPa pressure reduction valve (supplied by installer)
3	700 kPa ECV (supplied by installer)
4	High performance tempering valve (supplied by installer)
5	850 kPa PTR valve (pressure temperature relief)
6	Thermosiphon arrestor valve

**TIP:** The UV Solar Rated pipe insulation provided shall be used for the hot and cold arm assemblies.

## Insulation of Hot and Cold arm assembly

Using the supplied solar rated and UV stable insulation, cover all exposed  $\frac{3}{4}$  copper pipe and fittings to ensure maximum efficiency.

## Thermosiphon Arrestor Valve

The thermosiphon arrestor valve must be installed to prevent the system from over-heating. It shall be installed with the flow direction towards the inlet of the panels.

## Hot and Cold Water Connections

All plumbing connections must be performed by a licensed plumber in accordance with local authority regulations.

## Cold Water Connection

The cold water inlet connection to the solar storage tank is  $\frac{3}{4}$  FI. All pipes and valves must be insulated as per the current AS/NZ 3500.4 Section 8.2. The cold water inlet requires the following valve train please refer to system diagram page for correct installation

- Approved isolating/non return valve
- 500 kPa Pressure Reduction Valve (PRV) valve
- 700 kPa Expansion Control Valve (ECV)

The maximum inlet water pressure rating is 750kPa. Cold water supply pressures exceeding 500kPa a 500kPa Pressure Reduction valve shall be installed immediately downstream from the Duo valve.

## Hot Water Connection

The hot water outlet from the solar tank is  $\frac{3}{4}$  inch FI. All hot water pipes must be insulated by UV stable & appropriately rated insulation.

## Filling and commissioning the solar system

1. Turn on the cold water supply to the tank and open a hot water tap preferably laundry tap without filter as existing sediment may partially block pre-existing water saving devices.
2. Leave tap open until all air is bled, then turn off hot water tap.
3. Activate PTR Valve (Pressure relief valve) to ensure system is fully bled of all air
4. Once the system is fully pressurised with water, thoroughly check all fittings, connections and pipework for water leaks

1. Electric or Gas Boosted:

- Electric Boosted - Confirm electrical connection is properly terminated by authorised personal & switch on dedicated electrical circuit to ensure element circuit is operational. This can be checked by monitoring the existing homes power meter. This process shall only be completed after the tank is completely full of water and all air bled from the system. Failure to do so will cause damage to the electric element and will not be covered under warranty.
- Gas Boosted – Following manufacturers installation instructions located on the inside of the front cover

7. Check all water outlets in the home to ensure water supply is present at all fixtures.

## Overall System Dimensions

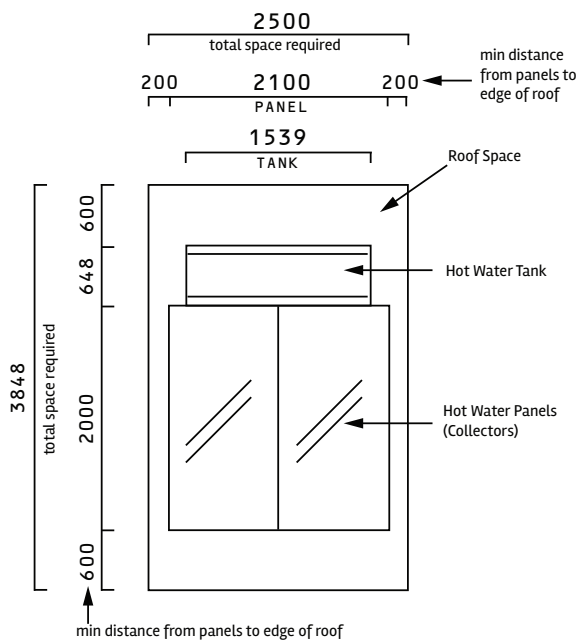

**A** Roof mounted Solar hot water (twin panel)

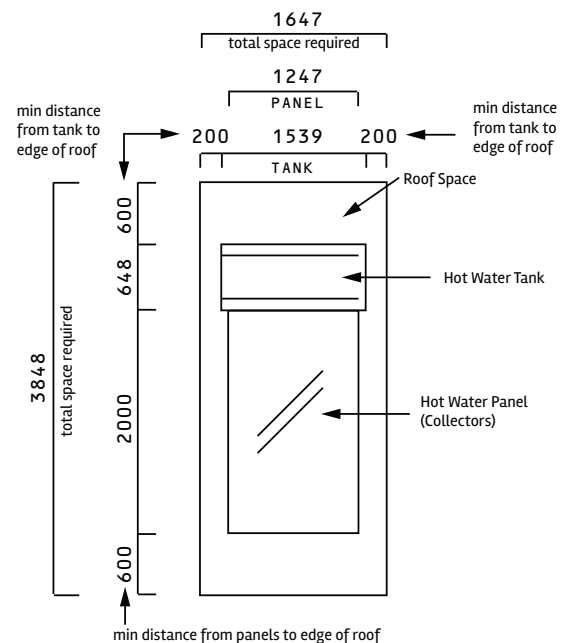

**B** Roof mounted solar hot water (single panel)

# Electrical Connections

Local codes including but not limited to AS/NZS 3000 must be adhered to for all electrical work and be undertaken by a licenced electrician. The electric element has a capacity of 2.4kW, paired with a thermostat to control the water temperature of the tank. When the water temperature in the tank reaches the normal setting 60°C, the thermostat will automatically disconnect & prevent overheating. The thermostat has a unique internal fuse protection that is designed especially for Solar Hot Water systems. The internal fuse is extra protection against any electrical malfunction & if the fuse activates, the thermostat will need to be replaced. The Solar Thermostat has an auto-reset-over-temperature cut-out for high solar contribution days & will automatically self-reset once the temperature drops below the maximum setting of 70°C.

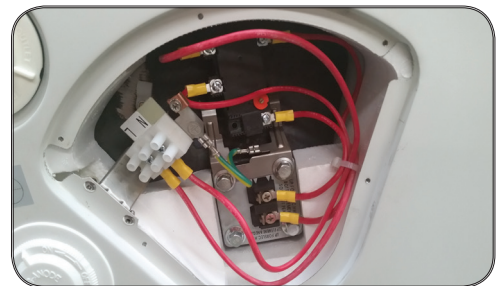
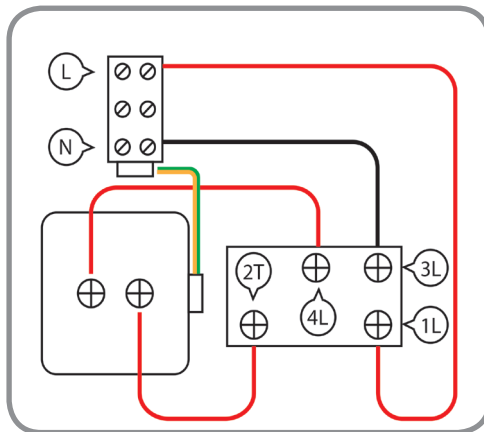

Incoming wiring shall be terminated as per Australian Standards & weather-proof cover shall be reinstalled after testing of the circuit by qualified personal. Under no circumstances shall the circuit be tested under load without the system being full of water.

Means for disconnection must be incorporated in the fixed wiring in accordance with the wiring rules.

The Solargain storage tank has a dedicated port for entry into the electrical provision, this is clearly marked by the supplied sticker on the external casing.



## Important

This drain hole shall not be used as a cable entry port. To do so will void the warranty of the system. Under no circumstances shall the drain hole be obstructed or modified in anyway.

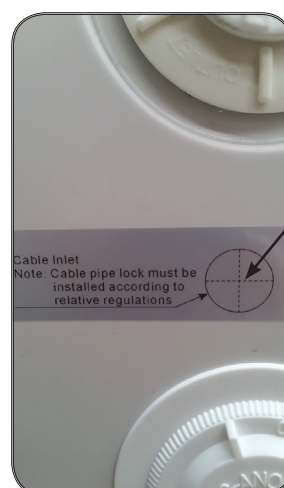

Provision for approved weather-proof connection as per Australian Standards

# Maintenance

Maintenance of the system is very easy and includes the following tasks: Temperature and Pressure Relief valve PTV (all tanks). The Solargain Hot Water system is fitted with an 850kPa PTR Valve, which is located on the side of the cylinder and is essential for its safe operation. It is important that you operate the easing knob or lift the lever on the PTR valve once every 6 months. It is important you rotate the knob or lever gently so seat is not damaged.

## Solargain Hot Water tanks

The five yearly service shall be carried out by a licensed tradesperson. It is recommended that this service is carried out by your local Solargain agent.

### The service should include the following:

- Replace the Pressure & temperature relief valve
- Replace the anode (anodes should be replaced more frequently if subjected to hard water conditions, refer table in the warranty exclusions, Solargain must be consulted regarding the replacement anode if not a genuine Solargain anode)
- Flush the water heater, clean panels of debris and or dust.
- Test element and thermostat for operation

### HOW TO DRAIN THE WATER HEATER

Warning: Before commencing this procedure, ensure that building occupants are notified to stay clear of the solar system components, roof and building perimeter as steam or hot water may be discharged from pipes or components

1. Turn off the electricity supply and tag out
2. Close the cold-water mains supply via the Isolation Valve
3. Release pressure from the system by activating the PTR valve and leave open by location the lever in the centre position
4. Disconnect the cold-water connection to the Thermosiphon Arrestor Valve
5. Remove the 22mm brass plug on the bottom of the collector array. For tiled roofs, ensure the water discharge path avoids joins or gaps in the roof structure as this may result in water ingress to the roof
6. Disconnect the water inlet and water outlet from the gas booster if applicable
7. The system will now drain all water

**Note: At this stage the water heater can be flushed by removing the element and hosing out any sediment.**

## Cleaning

Regular rain should keep the Solargain collector clean, but if particularly dirty then may be washed with a soft cloth and warm soapy water or glass cleaning solution. If the Solargain Collector is not easily and safely accessible, high pressure water spray is also effective.

## Leaves

During autumn leaves may accumulate between or beneath the Solargain Collector. Please remove these leaves regularly to ensure optimal performance and to prevent a fire hazard. Note: The solar collector will not cause the ignition of flammable materials.

## Insulation

Solar rated, UV stable insulation shall be used on all Solargain Hot Water system installations.

**Note:** Up to 60% heat loss can occur if the insulation is non-existent or substandard. Therefore please pay particular attention to making sure the system is properly insulated and any external insulation is UV Protected.

# Trouble Shooting

PROBLEM	SOURCE	SOLUTION
Water not as hot as previous hot water system	Tempering Valve installed	A tempering valve must be installed on every solar hot water system. Tempering valves will mix water down to 50°C.
No Hot Water	Electric or gas booster is not turned on or not configured correctly	Electric booster should be set to at least 60°C. Ensure circuit breaker is switched on. Ensure power is switched on to gas booster. Ensure mains gas supply hasn't been isolated.
Overflow pipe is dripping	Pressure Temperature Relief Valve (PTR) / Expansion Control Valve (ECV) where applicable.	An 850kPa and 99°C PTR valve is used on the Solargain water tank, which is located on the side of the water tank and is essential for its safe operation. The PTR valve is designed to allow 3-5% of total tank volume to discharge during heating to allow for hot water expansion.
Water pressure is slightly lower than previous hot water system	Pressure Reduction Valve (PRV)	A pressure reduction valve has been installed to limit the inlet pressure to your new Solargain Water Heater. This device regulates the incoming pressure & increases life of the cylinder. This device will also protect your cylinder if the mains pressure is increased by the local water authority.

## After Sales Service Guaranteed

Solargain pride ourselves in responsive after sales service, If the system is still not operating correctly. Under no circumstances should repairs be attempted by unqualified persons.

Thank you for joining Solargain in our mission to leading the way to a sustainable energy future.

Supplier Name: \_\_\_\_\_ Installation Date: \_\_\_\_\_

Supplier Address: \_\_\_\_\_ Supplier Phone: \_\_\_\_\_

System Model / Type: \_\_\_\_\_